

Motorised Cable Reels



Manufactured by **Cavotec Specimas**

Motorised Cable Reels

Who we are

Cavotec is a multi-national group of companies serving the following industries: mining and tunnelling, ports and maritime, steel and aluminium, energy and offshore, airports, general industry and automation. In the early 1960's our main focus was the design and production of motorised cable reels primarily for manufacturers of tower cranes, harbour cranes and mining equipment. Today, Cavotec is connecting mobile equipment around the world in many diverse applications.

Where we are

The Cavotec Group consists of 7 manufacturing "Centres of Excellence" located in Canada, France, Germany, Italy, Norway and Sweden and by 5 local manufacturing units located in Australia, China, Germany and the USA. For the distribution of products and providing support to customers Cavotec has 27 sales companies which, together with a network of distributors, serve more than 30 countries in five continents. The ultimate objective is to be perceived as "local everywhere".

How we work

Our aim is to work closely with our customers in order to build long-term partnerships. To achieve this aim we have created a working environment that attracts the best people, encourages them to stay and brings out their best qualities. By producing totally reliable systems and backing them with efficient service, we strive to create true customer satisfaction.



Motorised Cable Reels

Cable reels manufactured by Cavotec Specimas are today at work in ports, terminals, mines, tunnels and industries all over the world. The small factory located just outside Milan, Italy, which started its operations in 1963, has grown into a modern, large factory of 6000 m². Local manufacturing facilities of Cavotec Specimas products have been organised in Australia, China, Sweden, UK and USA.

A number of high level qualified engineers and technicians are engaged in research and development with the aid of the most advanced CAD and 3D design technology, which allows the company to maintain the innovative lead in its field. The range of Cavotec Specimas motorised cable reels covers any application and requirement of the modern industry.

Cavotec Specimas also produces a complete line of slipping columns as well as the Panzerbelt, an efficient and economic system for the protection of power cables in ports and terminals. Cavotec Specimas is committed to quality in products as well as in service. Its aim is to provide the highest quality standard, as confirmed by the ISO 9001 certificate received from TÜV, a well known German certification and approval organisation.

Cavotec Group Organization

As shown here the Cavotec Group is organized to support its customers around the world through its manufacturing units and local sales companies. Each Cavotec manufacturing company, no matter where it is located, aims at being a market leader in its field by providing innovative and reliable products to Group customers. Each Cavotec sales company, in the 27 countries where they operate, aims at better serving its local market following the Group philosophy "to be local everywhere".

Manufacturing network

Centres of Excellence

France

Cavotec RMS

Spring Driven Reels

Germany

Cavotec Alfo

Spring Driven Reels

Slipring Columns

Cavotec Fladung

Aircraft Support Systems

Security Systems

Italy

Cavotec Specimas

Motorized Cable Reels

Panzerbelt Cable Protection

Slipring Columns

Norway

Cavotec Micro-control

Radio Remote Controls

Sweden

Cavotec Connectors

Electrical Plugs & Sockets

New Zealand

Cavotec MoorMaster

Automated Mooring Systems

Local Manufacturing

Australia

Cavotec Australia

Motorized Cable Reels

China

Cavotec China

Product Assembly

Germany

Cavotec Micro-control

Radio Remote Controls

Sweden

Cavotec Sweden

Product Assembly

USA

Cavotec USA

Product Assembly

Group Partners

Belgium

Gantry

Crane Rail Systems

Italy

Brevetti Stendalto

Cable Chains

Prysmian (Pirelli)

Flexible Cables

Tratos Cavi

Flexible Cables

Sales network

Cavotec Sales Companies

Cavotec Australia

Cavotec Belgium*

Cavotec BeNeLux

Cavotec Brazil*

Cavotec Canada

Cavotec Chile

Cavotec China

Cavotec Denmark

Cavotec Finland

Cavotec France

Cavotec Germany

Cavotec Hong Kong

Cavotec India

Cavotec Italy

Cavotec Korea

Cavotec Latin America

Cavotec Mexico

Cavotec Middle East

Cavotec Norway

Cavotec Russia*

Cavotec Singapore

Cavotec South Africa

Cavotec Sweden

Cavotec Turkey

Cavotec UK & Ireland

Cavotec USA

* Branch Office



Contents

General Information	page 6
Guidelines for cable reels selection	page 8
INTERMITTENT DUTY	
Cavotec Hydrodynamic System	page 12
Cavotec Pull & Store System	page 18
CONTINUOUS DUTY	
Cavotec Torque Motor System	page 20
Cavotec Reel Control (CRC)	page 24
SPREADER REELS	
Cavotec Spreader Reels	page 28
MAIN REEL COMPONENTS	
Collectors 600V/1kV	page 30
KP Brush	page 30
Medium Voltage Collectors	page 31
Swivels	page 31
Fibre optic rotary accumulator	page 32
Cable Guides	page 33
The Cavotec Specimas Service	page 34

General Information

Milestones in innovation

- 1963 **Hydrodynamic Torque Unit**
First motorised cable reel using standard squirrel cage motor.
- 1965 **Adjustable Monospiral Drum**
First not fully welded and adjustable monospiral drum system.
- 1969 **Modular Reel**
First motorised reel produced in separate sub-components.
- 1973 **K-series signal collector**
Highly compact air insulated signal ring collector.
- 1975 **Panzerflex flexible cables**
Development of special reeling cable with Palazzo cable manufacturer.
- 1977 **Pull & Store cable reel**
- 1978 **Panzerbelt cable protection**
First flexible cable protection system for crane applications (patented).
- 1980 **KK-Collectors**
State of the art collector for harbour cranes.
- 1982 **Kp-brush system**
First multi-contact brush gear.
- 1986 **Electro-magnetic reel**
Introduction of electro-magnetic clutch designed especially for cable reel applications.
- 1992 **FO-Fibre optic rotary device**
Planetary fibre optic accumulator device (patented).
- 1993 **T-series gear-boxes**
For continuous duty applications.
- 1994 **Super Panzerbelt** (patented)
- 1994 **New Permanent Magnet Clutch design** (patented)
- 1995 **CTC - Cavotec Torque Control**
Technology for high speed reels.
- 1995 **Marine Propulsion Sliprings**
- 1996 **Spreader reels**
- 2002 **Cavotec Airport Caddy**
- 2003 **Alternative Maritime Power Supply Systems**
- 2005 **First Reels for 300 m/min continuous service**
- 2006 **Mooring Systems for Salalah**

Specimas was started in 1963 in Milan by Vittorio Baldoni, a creative Italian engineer who has given an acknowledged contribution to technological development in the field of motorised cable reels. The first customer of the company was Potain, the French world market leader in tower cranes, which is still today a key-customer after having purchased many thousands of Specimas reels.

Thanks to its highly innovative engineering ideas, Specimas became famous quickly: a tradition which has been kept alive through the years by more than 20 major innovations in cable reel technique, including well-known concepts such as Hydrodynamic torque units, Pull & Store reels, Panzerbelt cable protection system, and multi-contact brush-gear for collectors.

The first Cavotec company was incorporated in Sweden in 1974 as the distributor of Specimas and other electrical equipment, concentrating in power supply for mining and tunnelling, as well as crane equipment.

Ten years later in 1984, Cavotec AB, which in the meantime had become one of the major distributors of Specimas products, purchased Specimas. At this point it was decided to develop Specimas as a manufacturing company specialized in cable reels, while Cavotec concentrated in establishing a network of Cavotec sales and service companies for its world-wide marketing activities.

In 1990 the Cavotec Group purchased the cable reel manufacturing company CTA in Italy and established in Sweden Power Connectors AB, a company devoted to the production of industrial plugs & sockets. In 1997 the Group acquired Alfo GmbH, a German spring reel manufacturer, and in 1999 RMS S.A., a French hose reel manufacturer.

In 2001 Specimas changed its name to Cavotec Specimas. In the year 2002 the Cavotec Group acquired Gantrex USA, a major American manufacturer of rail fastening systems. In 2004 the Cavotec Group became the majority shareholder in Fladung GmbH a world leader in airport support systems.



Potain tower crane - 1966.



Guidelines for cable reel selection

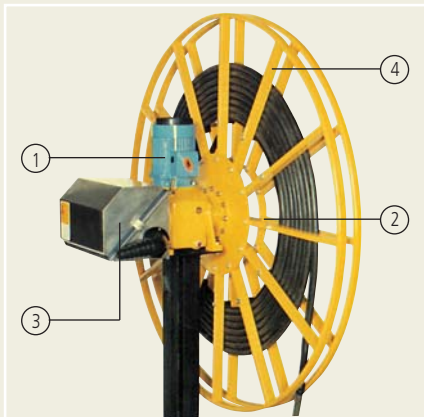

1. Motor (with drive)

Standard squirrel cage motor, according to IEC Norms. Alternatively, the cable reel can be supplied with a pneumatic or hydraulic motor.

2. Gearbox or Torque Unit

7 gearboxes and 8 torque units are available with variable output torque from 10-1200 daNm.

3. Collector

Standard sizes of collectors are available for power and signals, Current ratings vary from 10 to 2400 Amp, voltages from and voltages up to 30kV. We also manufacture custom-made collectors exceeding the above parameters.

4. Drum

Cavotec Specimas drums are composed of standard elements and can easily be adjusted to the required width. Standard drums sizes vary from 300 mm to 8700 mm diameter and more.

The correct selection of a motorised cable reel is of great importance. Cavotec Specimas engineers are at your disposal and can assist in an accurate selection for each and every application.

Motorised cable reels are usually divided into applications for Horizontal and Vertical Reeling, and a distinction is made between Intermittent Duty and Continuous Duty applications.

For Intermittent Duty applications, Cavotec Specimas normally uses the **Hydrodynamic System**, which is particularly suitable due to its simplicity and high reliability. Compact design, even torque output in reeling and unreeling mode, standard motor and low maintenance are some of the features of this system leading to the production of many thousands of units. Normal torque outputs are 10-700 daNm with speeds from 10-60 m/min.

For Continuous Duty applications, Cavotec Specimas uses the family of T-series gearboxes, which can be used with several drive systems. In order to optimise costs and technique, Cavotec Specimas uses different drive systems for different applications and sizes.

Typical selections are:

Torque Motor

for small reels and slow speed applications (5-40 daNm and 0-60 m/min).

Cavotec Reel Control (CRC)

for the largest reels (torque output 40-750 daNm).

Motorised cable reels normally consist of 5 main components, namely:

1. Motor (with drive)
2. Gearbox or Torque Unit
3. Collector
4. Drum
5. Cable guide

Cavotec Specimas reels can be fitted with different drums such as monospiral, random lay, parallel lay and Pull & Store configuration.

Collectors are available for low and high voltage, up to 30kV, with standard amperage capacities up to 2400 Amps. Motors are standard squirrel cage motors for all reels, except the torque motor reels. Motorised hose reels are also available in standard sizes for any pressures and for up to hose sizes 1/4" to 8".



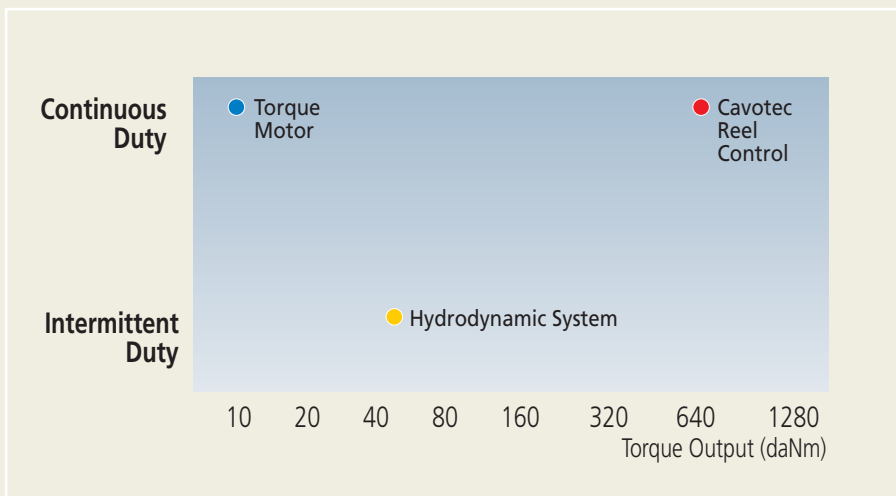

Range of Cavotec Specimas cable reel systems

The chart to the left shows the available Cavotec Specimas cable reel systems for **Continuous Duty** and **Intermittent Duty** applications and their normal working ranges.

For **Continuous Duty**, Cavotec Specimas can offer the following drives: Torque Motor and Cavotec Reel Control (CRC) - all using T-series gearboxes.

For **Intermittent Duty**, Cavotec Specimas offers its well-known Hydrodynamic System with a range of 8 torque units from 10 to 700 daNm these units can also be used for applications with higher duty cycles under certain circumstances.

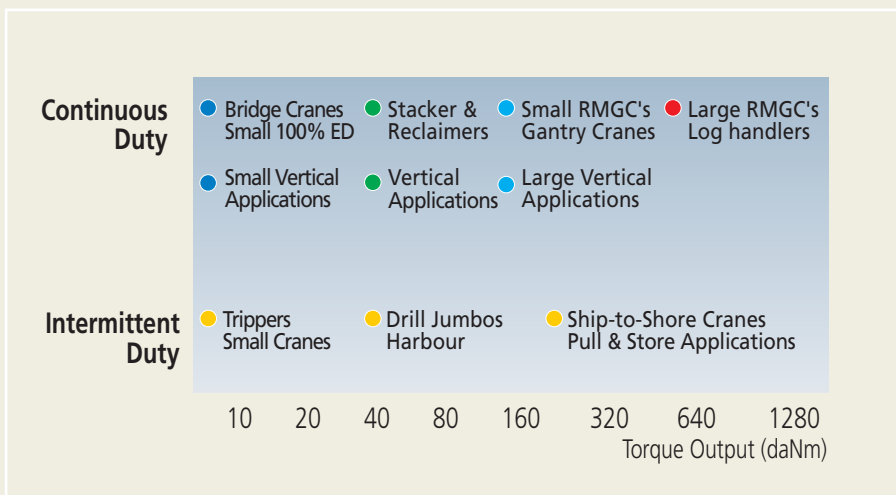

Typical cable reel applications

The chart to the left shows different typical cable reel applications related to the most suitable cable reel system and drive. Cavotec Specimas designs and supplies a great variety of motorised cable reels for almost any application. Production is based on a large number of standard sub-components which can be combined easily in order to satisfy most needs and requirements. Special designs are made on request.

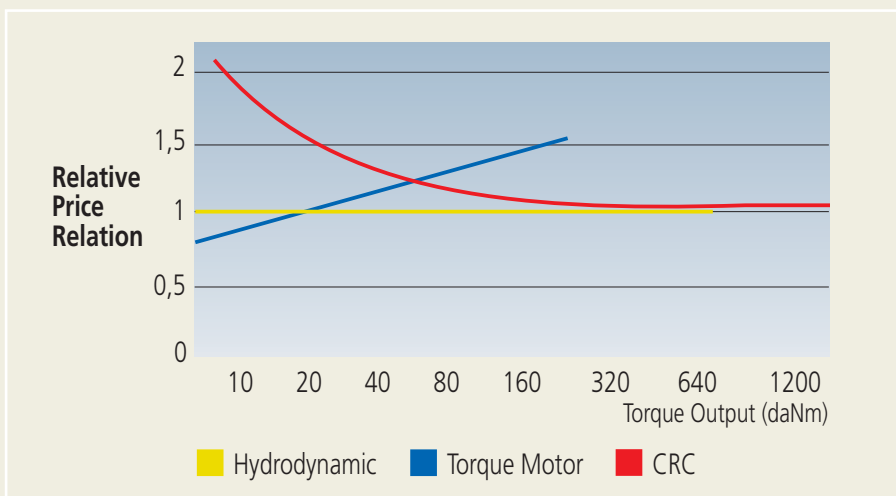

Cost-efficiency of the Cavotec Specimas cable reel systems

Since reeling application parameters (eg. speed, cable size, installation high) can vary greatly, it becomes necessary to use different systems and drives to satisfy all needs. These systems have also different cost-efficiencies, as illustrated in simple, but generalised terms, in the diagram to the left.

It is of great importance to choose the correct system for each application, in order to achieve optimal cost-efficiency. Our aim is to offer our customers the most suitable technical solution and the best quality at the lowest possible price.

From:	
Date:	Enquiry No
Person in charge:	

To:

CABLE & HOSE REEL – ENQUIRY FORM

Please provide as much information as possible. Assumptions will be made where data is incomplete

APPLICATION DESCRIPTION

Machine type:		Application/use:	
Machine main power supply	V/Hz	Max. simultaneous power consumption	kW
Machine control power supply	V/Hz	Cable reel duty cycle	ED%
Cable reel motor supply	V/Hz	Ambient temp. (min/max)	°C
Atmospheric conditions/presence of corrosive elements:			

CABLE DETAILS

Nominal cable voltage	V/AC	Hose internal diameter	mm <input type="checkbox"/> inch <input type="checkbox"/>
N° of cores and cross section	mm ²	Hose working pressure bar	psi <input type="checkbox"/> kPa <input type="checkbox"/> <input type="checkbox"/>
Cable outer diameter	mm	Hose outer diameter	mm
Cable weight	kg/m	Hose weight (empty)	kg/m
Max. allowable tension	N	Max. allowable tension	N
Optic fibres included	YES	Fluid carried	Type
Optic fibre type μm	N° of fibre:		

CABLE DETAILS

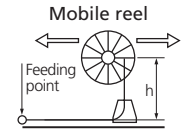
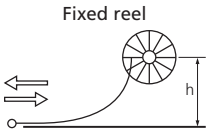
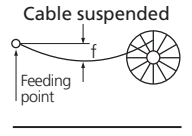
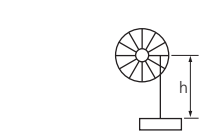
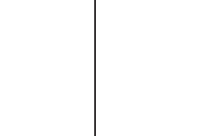
Horizontal Recovery (tick the applicable box)			Vertical Recovery (tick the applicable box)	
<input type="checkbox"/> Mobile	<input type="checkbox"/> Stationary	<input type="checkbox"/> f max=	<input type="checkbox"/> Vertical downwards	<input type="checkbox"/> Vertical upwards
				
Feed point location <input type="checkbox"/> Centre of runway <input type="checkbox"/> End of runway				
Active reeling length m			Active reeling length m	
Max. travel speed m/min			Max. hoist speed m/min	
Acceleration <input type="checkbox"/> m/sec ² <input type="checkbox"/> sec			Acceleration <input type="checkbox"/> m/sec ² <input type="checkbox"/> sec	
Installation height (h) m <i>(distance from drum centre to cable deposit level)</i>			Installation height (h) m <i>(total suspended length from drum centre to cable end)</i>	
Drum type: <input type="checkbox"/> Monospiral <input type="checkbox"/> Wide random lay <input type="checkbox"/> Level wind N° of cable dead turns				

Comments and Additional Requirements:



Cavotec Hydrodynamic System

INTERMITTENT DUTY

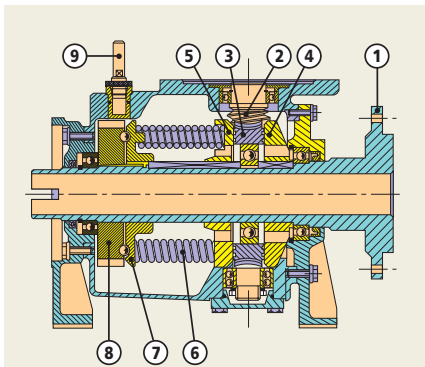

In the torque unit, represented in the sectional drawing above, the clutch is the main component which allows the constant torque output. The bronze crown gear (3), driven by the motorised worm screw (2), is freely mounted on the drum shaft (1). Its surfaces are specially machined. The two friction plates (4,5) are mounted on both sides of the crown gear. These are made of steel and are fixed to the drum shaft with a key.

The friction plates are also specially machined so that whilst turning, an oil film is created between the crown gear and the two plates, thus transmitting the torque to the drum shaft.

In order to adjust the clutch to obtain the required output, the torque unit has an adjustable spring assembly, which consists of the rear friction plate (5), a series of springs (6), the spring holder plate (7) and the torque regulating nut (8).

The rear friction plate is fixed to the drum shaft with a key, but can slide along the shaft axis. The torque regulating nut is screwed onto the drum shaft and pushes against the spring holder plate through a series of steel balls. The torque can therefore be adjusted by placing the torque regulating key (9) upside down into the torque unit. With the torque regulating nut held in position, the drum can be turned manually, thus increasing or decreasing the pressure on the spring assembly, and thereby increasing or decreasing the torque output of the clutch to the necessary output level.

The Cavotec Specimas hydrodynamic torque unit was introduced to the market in 1963. At the time it was the only alternative cable reel system to the traditional torque motor reels, and it was the first system which used conventional squirrel cage electric motors.

Still the most unique feature of the Cavotec Specimas hydrodynamic system is that its clutch is acting directly on the main drum shaft.

This gives an even torque output in reeling and unreeling modes, independently of clutch slip or reeling speed, thus assuring a long life for the cable.

The diagram below shows the typical torque/speed diagram for a hydrodynamic torque unit with an unbeaten even torque output. The torque variation due to slip or reeling speed does not exceed 5-10% depending on the torque unit size.

Due to its unique patented design, the Cavotec Specimas hydrodynamic system provides a simple and rational solution for many cable and hose reel applications. The system is based on a gearbox in which a reduction gear, clutch and brake are built as one unit. It provides a constant torque output, allowing an even recovery of any type of cable.

The Cavotec Specimas hydrodynamic cable reel is driven by a standard squirrel cage motor but can also be supplied with a hydraulic or pneumatic motor.

Another major advantage is that the torque can easily be readjusted on site. This way, the tension of the cable may be reduced or increased according to the actual requirements.

Cavotec Specimas hydrodynamic cable reels are at work throughout the world on harbour cranes, container cranes, mining machines and mobile cranes.

Torque/speed diagram

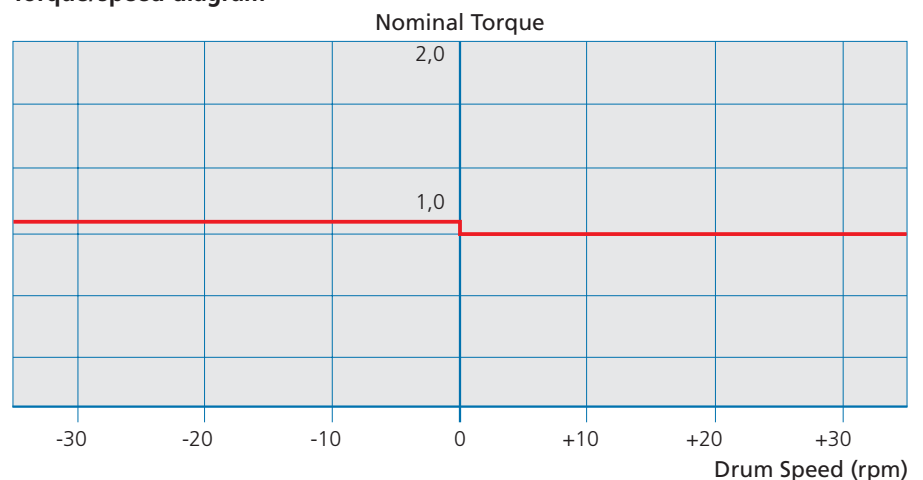



Hydrodynamic Reels - Low Voltage

INTERMITTENT DUTY

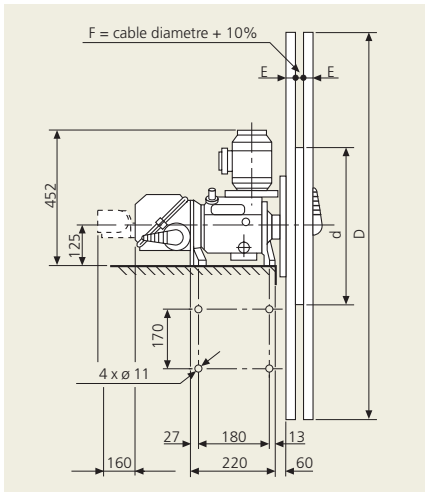

Torque unit 10.0

Reduction 1:42 – Nominal torque 100 Nm
weight: 35 kg

Motor (values for 400V, 50Hz)			Flange Size 80		Collector 600 V, IP 55			
No. of poles/rpm	kW	Amp	Reel speed (m/min)		Type	K12	K412	K424
			d=300	d=500				
4/1410	0,75	2,1	32	53	N° rings	12	4	4
6/920	0,55	1,8	21	35	Nominal amperage Amp	30	120	240
8/700	0,18	1,0	15	26	Continuous rating Amp	16	60	120
Motor weight: 9 Kg					Weight Kg	9	8	TBC

Drum dimensions				Approximate weight (Kg)	Monospiral reel					
D	d	E	Type		Capacity (metres)					
700	300	20	15	10.0 M 307	7	6	9	9		
900	300	20	17	10.0 M 309	16	14	20	18	13	10
1000	500	40	20	10.0 M 510	18	15	22	20	15	12
1200	500	40	24	10.0 M 512	31	27	36	34	25	21
1400	500	40	28	10.0 M 514	46	40	54	51	38	32
1600	500	40	39	10.0 M 516	64	56	75	71	54	46

These tables only give an indication of general capacity and size. Always ask Cavotec Specimas for a specific quotation.

Cable size	mm ²	7x 2,5	12x 2,5	4x 4	4x 6	4x 10	4x 16
Outer diameter	~ mm	24	27	21	22	28	32
Amperage rating	~ Amp	24	24	33	43	60	80
Weight	~ kg	0,7	0,9	0,55	0,7	1,1	1,5

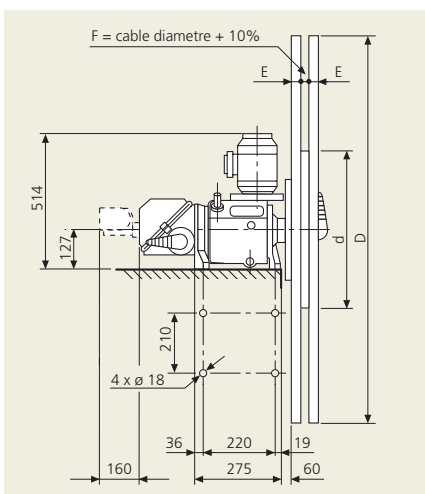

Torque unit 20.0

Reduction 1:60 – Nominal torque 200 Nm
weight: 55 kg

Motor (values for 400V, 50Hz)			Flange Size 80		Collector 600 V, IP 55			
No. of poles/rpm	kW	Amp	Reel speed (m/min)		Type	K12	K412	K424
			d=300	d=500				
4/1420	1,5	3,7	37	60	N° rings	24	4	4
6/930	1,1	3,4	24	39	Nominal amperage Amp	30	240	400
8/700	0,55	2,3	18	29	Continuous rating Amp	16	120	200
Motor weight: 15 Kg					Weight Kg	9	9	12

Drum dimensions				Approximate weight (Kg)	Monospiral reel					
D	d	E	Type		Capacity (metres)					
1000	500	40	20	20.0 M 510	13	10	12			
1200	500	40	24	20.0 M 512	22	18	22			
1400	500	40	28	20.0 M 514	34	28	33	27		
1600	800	40	40	20.0 M 816	40	34	40	32	29	23
1900	800	40	52	20.0 M 819	64	54	64	52	47	39
2200	800	40	63	20.0 M 822	93	79	92	75	68	57

These tables only give an indication of general capacity and size. Always ask Cavotec Specimas for a specific quotation.

Cable size	mm ²	18x 2,5	24x 2,5	4x 16	4x 25	4x 35	3x50 + 3x10
Outer diameter	~ mm	31	35,6	31,2	37,1	40,3	46,7
Amperage rating	~ Amp	14,4	12,8	83	110	137	170
Weight	~ kg	1,27	1,67	1,47	2,16	2,72	3,4

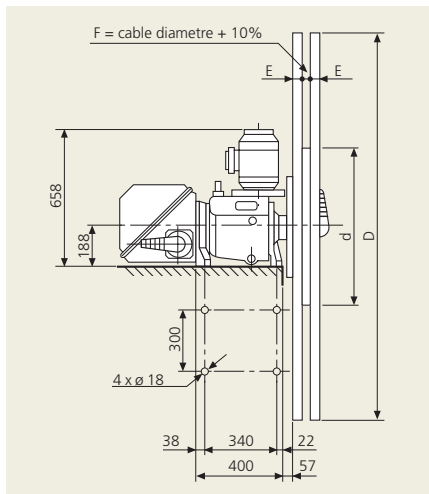

Torque unit 40.0

Reduction 1:63 – Nominal torque 400 Nm
weight: 125 kg

Motor (values for 400V, 50Hz)		Flange Size 100/112		Collector 600 V, IP 55					
No. of poles/ rpm	kW	Amp	Reel speed (m/min)		Type	K24	K440	K460	
			d=800	d=1200					
4/1430	3,0	6,9	57	86	N° rings	24	4	4	
6/930	2,2	5,8	37	56	Nominal amperage Amp	30	400	600	
8/690	1,5	4,6	28	42	Continuous rating Amp	16	200	300	
Motor weight: 23-31 Kg					Weight	Kg	9	12	35

Drum dimensions			Approximate weight (Kg)	Monospiral reel		Capacity (metres)						
D	d	E		Type								
1400	500	40	28	40.0 M 514	34	28	24	19	17	15		
1600	800	40	40	40.0 M 816	40	34	29	23	21	19		
1900	800	40	52	40.0 M 819	64	54	47	39	34	32		
2200	800	40	63	40.0 M 822	93	79	68	57	51	47		
2500	1200	60	136	40.0 M 1225	109	93	81	68	61	57		
2800	1200	60	148	40.0 M 1228	147	126	110	93	83	78		

These tables only give an indication of general capacity and size. Always ask Cavotec Specimas for a specific quotation.

Cable size	mm ²	18x 2,5	24x 2,5	4x 35	3x50 + 3x10	3x70 + 3x16	3x95 + 3x16
Outer diameter	~ mm	31	35,6	40,3	46,7	51,4	54,2
Amperage rating	~ Amp	14,4	12,8	137	170	210	254
Weight	~ kg	1,27	1,67	2,72	3,4	4,4	5,5

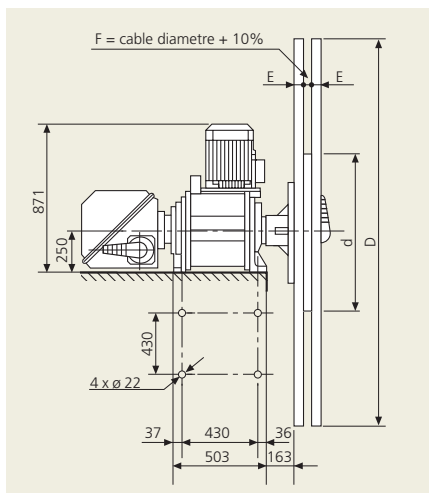

Torque unit 120.0

Reduction 1:90 – Nominal torque 1200 Nm
weight: 316 kg

Motor (values for 400V, 50Hz)		Flange Size 132		Collector 600 V, IP 55					
No. of poles/ rpm	kW	Amp	Reel speed (m/min)		Type	K12	K412	K424	
			d=1200	d=1500					
4/1440	7,5	16	60	75	N° rings	4	4	4	
6/940	5,5	12,7	39	49	Nominal amperage Amp	400	600	1200	
8/710	3,8	9	29	37	Continuous rating Amp	200	300	600	
Motor weight: 50 Kg					Weight	Kg	12	35	48

Drum dimensions			Approximate weight (Kg)	Monospiral reel		Capacity (metres)						
D	d	E		Type								
2200	800	40	63	120.0 M 822	68	57	51	47	40	39		
2500	800	40	75	120.0 M 825	93	78	70	65	56	54		
3100	1200	60	160	120.0 M 1231	142	120	107	101	88	85		
3800	1200	80	360	120.0 M 1238	230	196	176	165	144	139		
4000	1500	100	380	120.0 M 1240	246	209	188	177	155	149		
4300	1500	100	450	120.0 M 1543	292	249	224	211	184	178		

These tables only give an indication of general capacity and size. Always ask Cavotec Specimas for a specific quotation.

Cable size	mm ²	4x 35	3x50 + 3x10	3x70 + 3x16	3x95 + 3x16	3x120 + 3x25	3x150 + 3x25
Outer diameter	~ mm	40,3	46,7	51,4	54,2	61,1	62,9
Amperage rating	~ Amp	137	170	210	254	296	340
Weight	~ kg	2,72	3,4	4,4	5,5	6,8	7,94

Hydrodynamic Reels - Low Voltage

INTERMITTENT DUTY

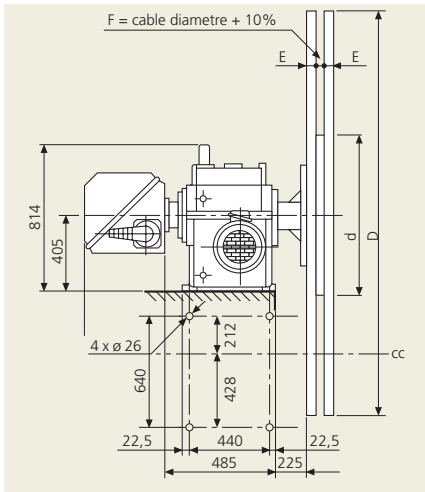

Torque unit 200.0/300.0

Reduction 1:186/1:237 – Nominal torque 2000/3000 Nm
weight: 610 kg

Motor (values for 400V, 50Hz)			Flange Size 132			Collector 1000 V, IP 55			
No. of poles/rpm	kW	Amp	Reel speed (m/min)			Type	K440	K460	K4121
			d=1500	d=1800	d=2000				
4	7,5	16,5	36	28	48	N° rings	4	4	4
6	5,5	12,7	23	18	31	Nominal amperage Amp	400	600	1200
8	3,8	9	17	14	23	Continuous rating Amp	16	60	120
Motor weight: 50 Kg						Weight Kg	12	35	48

Drum dimensions			Approximate weight (Kg)	Monospiral reel		Capacity (metres)				
D	d	E		Type						
3500	1200	80	320	200.0/300.0 M1235	190	161	145	136	118	114
3800	1200	80	360	200.0/300.0 M1238	230	196	176	165	144	139
4300	1500	100	450	200.0/300.0 M1543	292	249	224	211	184	178
5000	1500	100	640	200.0/300.0 M1550	352		317	300	262	254
5500	2000	120	820	200.0/300.0 M2055			371	350	307	298
6000	2000	120	1160	200.0/300.0 M2060			455	430	377	365

These tables only give an indication of general capacity and size. Always ask Cavotec Specimas for a specific quotation.

Cable size	mm ²	4x 35	3x50 + 3x10	3x70 + 3x16	3x95 + 3x16	3x120 + 3x25	3x150 + 3x25
Outer diameter	~ mm	40,3	46,7	51,4	54,2	61,1	62,9
Amperage rating	~ Amp	137	170	210	254	296	340
Weight	~ kg	2,72	3,4	4,4	5,5	6,8	7,94

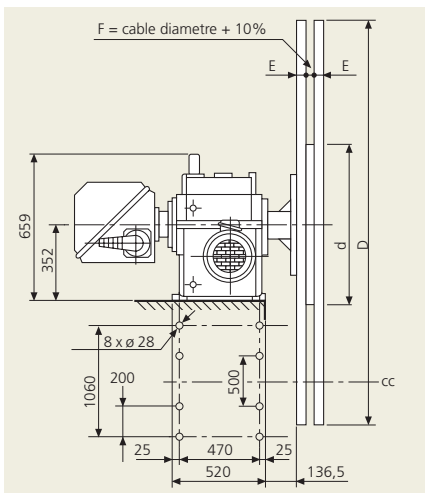

Torque unit 550.0/700.0

Reduction 1:202/1:256 – Nominal torque 5500/7000 Nm
weight: 1000 kg

Motor (values for 400V, 50Hz)			Flange Size 132			Collector 1000 V, IP 55			
No. of poles/rpm	kW	Amp	Reel speed (m/min)			Type	K440	K460	K4121
			d=2000	d=2500	d=3000				
4	7,5	16,5	44	35	67	N° rings	4	4	4
6	5,5	12,7	29	23	43	Nominal amperage Amp	400	600	1200
8	3,8	9	22	17	33	Continuous rating Amp	16	60	120
Motor weight: 50 Kg						Weight Kg	12	35	48

Drum dimensions			Approximate weight (Kg)	Monospiral reel		Capacity (metres)				
D	d	E		Type						
6000	2000	100	1160	550.0/700.0 M2060	589	504	455	430	377	365
6500	2500	120	1550	550.0/700.0 M2560	667	571	516	488	429	415
6500	2500	120	1550	550.0/700.0 M2565	667	571	516	488	429	415
7000	2500	120	2000	550.0/700.0 M2570	681		615	581	511	496
7300	2500	150	2500	550.0/700.0 M2573			678	641	564	547
7300	3000	150	2500	550.0/700.0 M3073			640	605	533	516

These tables only give an indication of general capacity and size. Always ask Cavotec Specimas for a specific quotation.

Cable size	mm ²	4x 35	3x50 + 3x10	3x70 + 3x16	3x95 + 3x16	3x120 + 3x25	3x150 + 3x25
Outer diameter	~ mm	40,3	46,7	51,4	54,2	61,1	62,9
Amperage rating	~ Amp	137	170	210	254	296	340
Weight	~ kg	2,72	3,4	4,4	5,5	6,8	7,94

Hydrodynamic Reels - Medium Voltage

INTERMITTENT DUTY

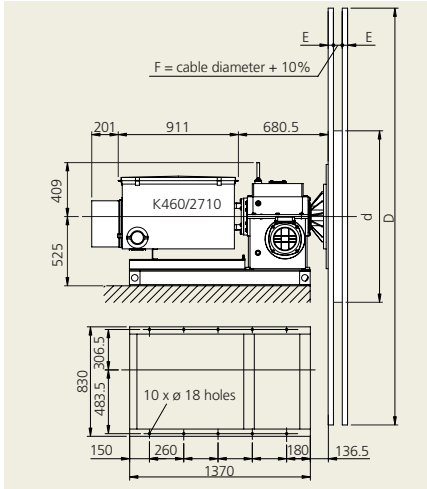

Torque unit 200.0/300.0

Reduction 1:186/1:237 – Nominal torque 2000/3000 Nm
weight: 610 kg

Motor (values for 400V, 50Hz)			Flange Size 132		Collector 1000 V, IP 55				
No. of poles/rpm	kW	Amp	Reel speed (m/min)		Type	K460/2710	K460/2713	K460/4522	
			d=1500	d=2000					
4	7,5	16,5	36	28	48	38			
6	5,5	12,7	23	18	31	24			
8	3,8	9	17	14	23	18			
Nominal voltage						kV	6	10	20
Max. voltage						kV	7,2	12	24
N° rings							4	4	4
Nominal amperage						Amp	600	600	600
Continuous rating						Amp	300	300	300
Motor weight:						Kg	190	210	350
Weight (basement included)						Kg	190	210	350

Drum dimensions				Approximate weight (Kg)	Monospiral reel					
D	d	E	Type		Capacity (metres)					
3500	1200	80	320	200.0/300.0 M1235	145	98	136	96	104	94
3800	1200	80	360	200.0/300.0 M1238	176	120	165	118	127	115
4300	1500	100	450	200.0/300.0 M1543	224	154	210	151	163	147
5000	1500	100	640	200.0/300.0 M1550	318	219	299	216	233	211
5500	2000	120	820	200.0/300.0 M2055	372	258	350	254	273	248
6000	2000	120	1160	200.0/300.0 M2060	456	317	429	312	336	305

These tables only give an indication of general capacity and size. Always ask Cavotec Specimas for a specific quotation.

Cable size	mm ²	3x35 3x10	3x120 3x25	3x25 3x10	3x95 3x25	3x35 3x10	3x50 3x10
Outer diameter	~ mm	40,3	46,7	51,4	54,2	61,1	62,9
Amperage rating	~ Amp	137	170	210	254	296	340
Weight	~ kg	2,72	3,4	4,4	5,5	6,8	7,94

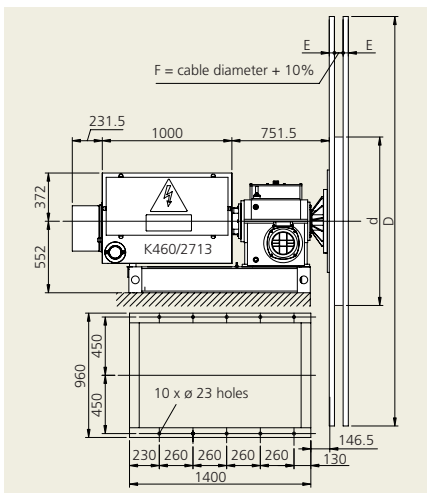

Torque unit 550.0/700.0

Reduction 1:202/1:256 – Nominal torque 5500/7000 Nm
weight: 1000 kg

Motor (values for 400V, 50Hz)			Flange Size 132		Collector 1000 V, IP 55				
No. of poles/rpm	kW	Amp	Reel speed (m/min)		Type	K460/2710	K460/2713	K460/4522	
			d=1500	d=2000					
4	7,5	16,5	44	35	67	52			
6	5,5	12,7	29	23	43	34			
8	3,8	9	22	17	33	26			
Nominal voltage						kV	6	10	20
Max. voltage						kV	7,2	12	24
N° rings							4	4	4
Nominal amperage						Amp	600	600	600
Continuous rating						Amp	300	300	300
Motor weight:						Kg	190	210	350
Weight (basement included)						Kg	190	210	350

Drum dimensions				Approximate weight (Kg)	Monospiral reel					
D	d	E	Type		Capacity (metres)					
6000	2000	100	1160	550.0/700.0 M2060	456	317	429	312	336	305
6500	2500	120	1550	550.0/700.0 M2560	517	361	487	355	382	347
6500	2500	120	1550	550.0/700.0 M2565	517	361	487	355	382	347
7000	2500	150	2000	550.0/700.0 M2570	616	431	580	424	456	414
7300	2500	150	2500	550.0/700.0 M2573	680	476	640	468	503	457
7300	3000	150	2500	550.0/700.0 M3073	641	449	604	443	475	432

These tables only give an indication of general capacity and size. Always ask Cavotec Specimas for a specific quotation.

Cable size	mm ²	3x35 3x10	3x120 3x25	3x25 3x10	3x95 3x25	3x35 3x10	3x50 3x10
Outer diameter	~ mm	51,3	71,6	54,3	72,6	68	74,2
Amperage rating	~ Amp	130	281	105	240	137	172
Weight	~ kg	3,54	8,21	3,38	7,14	5,44	6,22

Cavotec Pull and Store System

INTERMITTENT DUTY

Cavotec Specimas Pull and Store reels are today working all over the world in about 1200 installations. The system has provided a simple solution to the problem of cable over-tensioning in high lift applications. The motorised Pull reel lifts the cable with constant reeling radius, while the Store reel collects the cable on the main drum.

By splitting the work to Pull and to Store the cable on two separate torque units –

each with even torque output – Cavotec Specimas introduced in 1977 a simple system for cable protection. The system becomes intrinsically safe, featuring an integrated over tension limitation, without the need for more sophisticated and sensitive torque control systems. The Pull & Store can also be supplied with CRC drives on both units.

Standard Pull and Store configuration

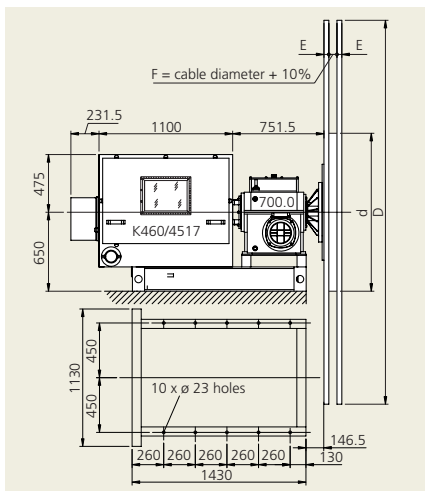
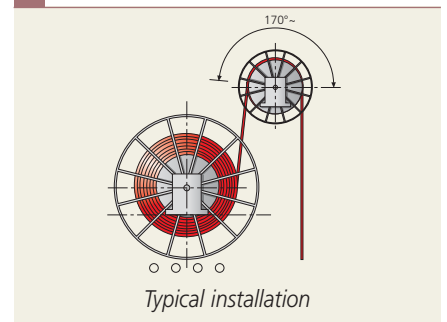

Store reel

		Collector MV, IP 55		
		Nominal voltage		
		6kV	10kV	20kV
		N° rings		
		4	4	4
		Nominal amperage Amp		
		600	600	600
		Continuous rating Amp		
		300	300	300

Drum dimensions	D	d	E	Approximate weight (Kg)	Store reel Type	Reeling Capacity (metres)					
6000	2000	100	1160	1160	300.0 M 2060	378	347	365	341	336	306
6500	2000	120	1150	1150	300.0 M 2065	454	417	439	410	404	368
7000	2500	150	2000	2000	550.0 M 2570	512	471	495	463	456	416
7500	2500	150	2500	2500	550.0 M 2573	565	519	546	511	503	459
7300	3000	150	2500	2500	700.0 M 3073	534	491	516	483	475	434
8500	4000	180	4000	4000	700.0 M 4085	686	631	663	621	612	559

These tables only give an indication of general capacity and size. Always ask Cavotec Specimas for a specific quotation.

Cable size	mm ²	3x70	3x95	3x50	3x70	3x35	3x50
Outer diameter	~ mm	61	66	63	67	68	74
Amperage rating	~ Amp	220	268	178	220	143	178
Weight	~ kg	5,6	6,6	4,9	5,9	5,4	6,2

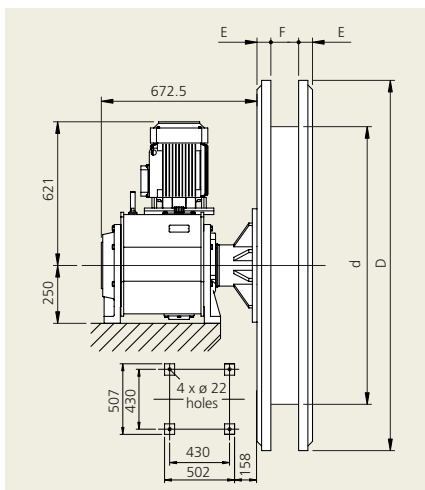

Pull reel

Drum dimensions	D	d	E	F	Approximate weight (Kg)	Pull reel Type	Lifting Capacity (metres)					
1600	1200	40	120	50	50	40.0 P 1216	7	6	8	6	7	6
1900	1500	50	120	58	58	120.0 P 1519	17	14	20	16	18	15
2200	1800	50	120	65	65	120.0 P 1822	14	12	16	13	15	13
2400	2000	60	120	100	100	200.0 P 2024	26	22	30	24	27	23

Comparison of cable tensions between Monospiral and Pull and Store reels

If the cable tension is not monitored and controlled it will vary in a reel application mainly due to the characteristics of the clutch, the reeling diameter and the inertia of the drum and cable. Below follows a comparison of Monospiral and Pull and Store application using the hydrodynamic torque units. The data used are for a typical application on a ship-to-shore crane.

Application data

Type of crane	Ship-to-shore crane
Cable	11 kV diameter 58 mm weight 5,1 kg
Cable length	460 m
Speed	46 m/min
Acceleration time	5 s
Height of installation	20 m
Duty cycle (travel)	40 % ED



Pull and Store reels in action at Everglades Terminal, USA.

Monospiral reel

The diagram to the right shows the cable tension as a function of the number of turns of the cable on the drum in a monospiral application. In a monospiral reel with a constant torque output the cable tension increases as the reeling diameter decreases. This varies also depending on the reeling or unreeling mode. As illustrated here it is not unusual that the maximum tension allowed on the cable is exceeded in a monospiral application - especially when there is a big ratio between drum inner and outer diameter.

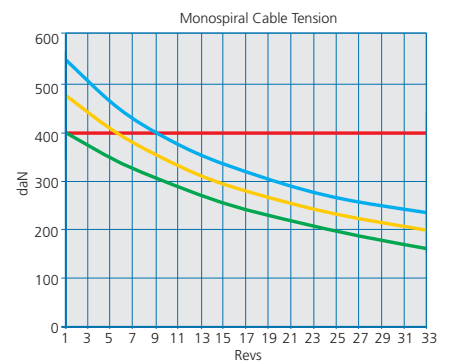
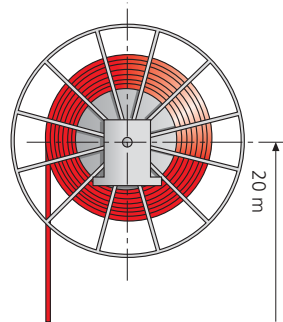

Pull and Store reel

The diagram to the right shows the cable tension as a function of the number of turns of the cable on the drum in a Pull and Store system based on the same data as above. In the Pull and Store reel, the cable tension is limited mainly by the fact that the Pull reel lifts the cable with a constant radius. It varies also depending on the reeling or unreeling mode and due to inertia of drum and cable. Through the use of a Pull and Store configuration it is possible to limit the maximum tension of the cable within the allowed limits, as shown in the diagram, without the need of sophisticated torque control.

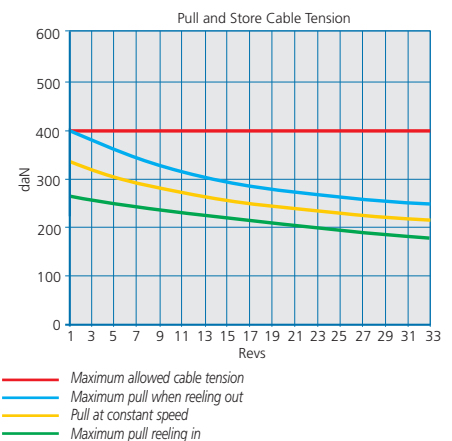
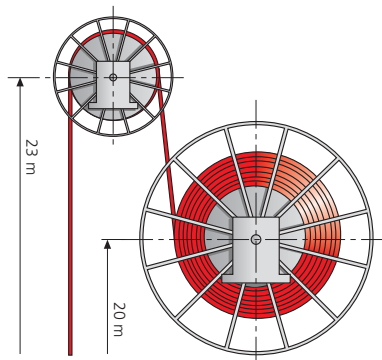

— Maximum allowed cable tension
 — Maximum pull when reeling out
 — Pull at constant speed
 — Maximum pull reeling in

Cavotec Torque Motor System

CONTINUOUS DUTY

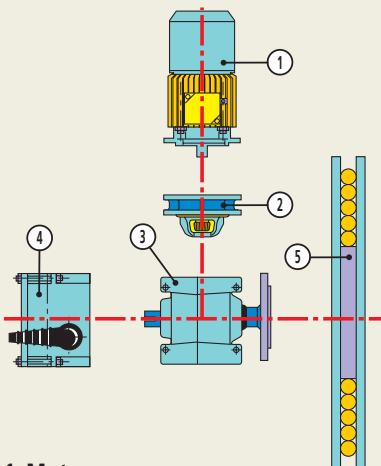

1 Motor

Self-braking torque motor

2 Pre-reducer

Mounted between torque motor and main gearbox to adapt motor torque and speed to required values.

3 Gearbox

This is the basic component of the Cavotec Specimas system. It adapts motor speed and torque to the requirement of the application

4 Collector

The purpose of the sliping assembly is to allow the reeling of the cable onto the drum without torsional strain. Cavotec Specimas sliping assemblies are monobloc units, they are self-contained and fitted directly onto the torque unit shaft.

5 Drum

Cavotec Specimas drums are of modular design, using standard components, offering a wide range of selections. Drums are manufactured from steel tubing and surface treated to withstand tropical and corrosive marine conditions. Drums with small diameters are manufactured from sheet and are welded. All assembly bolts are in stainless steel.

The Cavotec Specimas torque motor for cable reels has been designed to provide a virtually constant torque in reeling and unreeling mode. The system is also designed for continuous duty. The resulting mechanical cable tension could be compared to a hydrodynamic system. This has been obtained by using a torque motor with a very flat torque/slip curve. The motors are used up to maximum of ± 400 rpm and, within this range, the torque fluctuation is approximately 10%. Besides the motor characteristics, the gearbox

efficiency also influence the traction to which the cable is submitted. The Cavotec Specimas T-series gearboxes are designed with this in mind. They incorporate a monoshaft planetary gear which makes them highly reversible. The torque motors are equipped with an electro-magnetic brake and are servo-ventilated. The standard protection class is IP55 and the motors are suitable for environment temperatures up to 40°C. Special ventilation and motor insulation are supplied for higher temperature ranges.

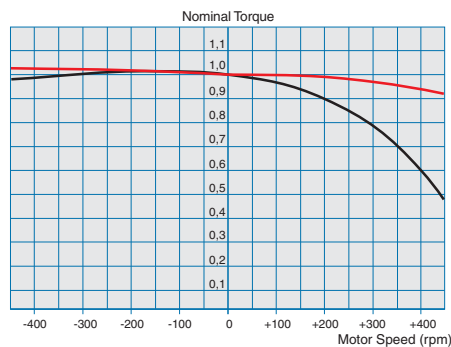

Torque/slip diagram

— Cavotec Specimas torque motor
— Conventional torque motor

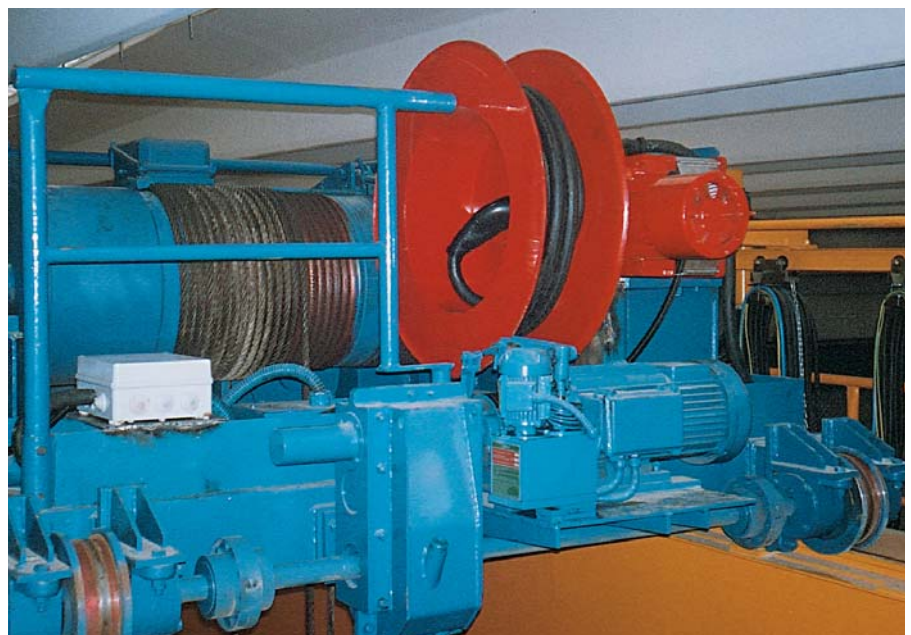

A vertical reel application at work in a steel mill.

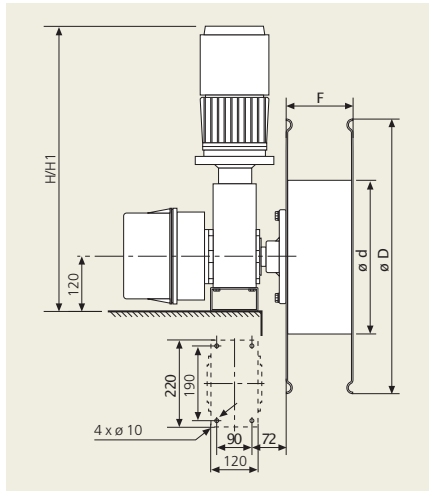

Reducer T2 with torque motor

Nominal torque 100 Nm

Reducer T2			Reeling speed (m/min)			Collector 600 V, IP55				
Type	Reduction	Approximate weight (kg)	d=300	d=400	d=500	Type	KA4512	KA0204	KA0304	
T2.10	10,3	20	36	48	61	N° rings	11+P	3+P	3+P	
T2.14	14,1	20	27	35	45	Nominal amperage Amp	25	50	90	
T2.23	23,1	20	16	22	27	Continuous rating Amp				
Weight							kg	4	3,5	5

Torque motors 400V (±5%) - 50 Hz (±400 rpm)						Drum				
Type	Nominal torque Nm	Approx. weight (kg)	Amp	H	H1	Type	dimension D d F	Approx. weight(kg)	Capacity (metres)	
N2	2	14	0,63	703	760	TF306	600 300 100	15	29 25	30 28
N3	3	20	0,84	750	819	TF306	600 300 150	16	43 37	45 42
N5	5	28	1,28	785	865	TF306	600 300 200	18	58 50	61 56
N7	7	35	2,72	860	1007	TF306	600 300 200	18	52 44	55 51
						TF408	800 400 100	25	78 66	82 76
						TF408	800 400 150	28	104 89	110 102
						TF408	800 400 200	33		

These tables only give an indication of general capacity and size. Always ask Cavotec Specimas for a specific quotation.

Cable size	mm²	7x	12x	4x	4x	4x	4x
Outer diameter	~ mm	2,5	2,5	4	6	21,5	30
Amperage rating	~ Amp	24	24,8	33	43	60	80
Weight	~ kg	0,7	0,9	0,55	0,68	1,03	1,47

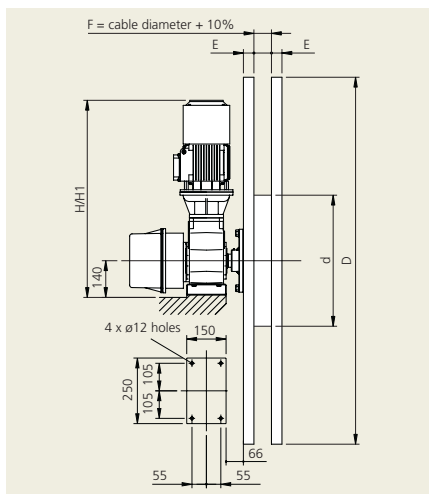

Reducer NT3 with torque motor

Nominal torque 290 Nm

Reducer T3N			Reeling speed (m/min)		Collector 600 V, IP55			
Type	Reduction	Approximate weight (kg)	d=300	d=500	Type	K12	K412	K424
NT3.09	9,3	24	40	67	N° rings	12	4	4
NT3.14	13,6	24	27	46	Nominal amperage Amp	30	120	240
NT3.23	22,8	24	16	27	Continuous rating Amp	16	60	120
NT3.23	29,3	24	12	21	Weight	kg	9	7

Torque motors 400V (±5%) - 50 Hz (±400 rpm)						Drum				
Type	Nominal torque Nm	Approx. weight (kg)	Amp	H	H1 ⁽¹⁾	Type	dimension D d E	Approx. weight (kg)	Capacity (metres)	
N2	2	17	0,63	575	625	M307	700 300 20	15	7 6	9 9
N3	3	18	0,84	620	670	M309	900 300 20	17	16 14	20 18
N5	5	26	1,28	655	705	M510	1000 500 40	20	18 15	22 20
N6	6	26	1,71	655	705	M512	1200 500 40	24	31 27	36 34
N7	7	30	2,72	730	780	M514	1400 500 40	28	46 40	54 51
N8.6	8,6	38	3,32	730	780	M516	1600 500 40	39	64 56	75 71
N10	10	45	3,63	855	905					

These tables only give an indication of general capacity and size. Always ask Cavotec Specimas for a specific quotation.

Cable size	mm²	7x	12x	4x	4x	4x	4x
Outer diameter	~ mm	24	27	21	22	28	32
Amperage rating	~ Amp	24	24	33	43	60	80
Weight	~ kg	0,7	0,9	0,55	0,7	1,1	1,5
Drum width F	mm	26	29	23	24	30	35

Cavotec Torque Motor System

CONTINUOUS DUTY

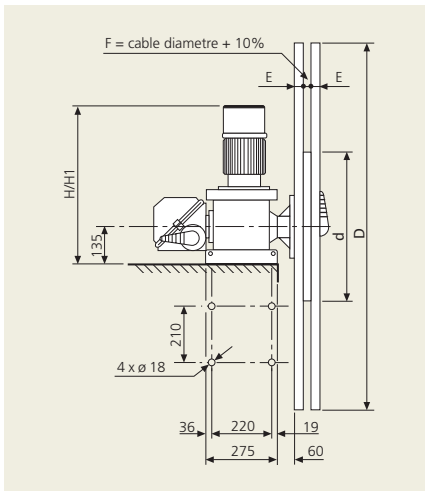

Reducer T4 with torque motor Nominal torque 500 Nm

Reducer T4				Reel speed (m/min)			Collector 600 V, IP55		
Type	Reduction	Approximate weight (kg)	d=500	d=800	Type	K24	K424	K440	
T4.0	15	75	41	66	N° rings	24	4	4	
T4.1 ⁽¹⁾	23	91,5	27	43	Nominal amperage Amp	30	240	400	
T4.2 ⁽¹⁾	30	91,5	20	33	Continuous rating Amp	20	120	200	
T4.3 ⁽¹⁾	38	91,5	16	26	Weight kg	9	9	12	

Torque motors 400V (±5%) - 50 Hz (±400 rpm)						Drum								
Type	Nominal torque Nm	Approx. weight (kg)	Amp	H	H1 ⁽¹⁾	Type	dimension D d E	Approx. weight(kg)	Capacity (metres)					
N5	5	26	1,28	703	780	M510	1000 500 40	20	13	10	12			
N6	6	26	1,71	703	780	M512	1200 500 40	24	22	18	22			
N7	7	30	2,72	778	855	M514	1400 500 40	28	34	28	33	27		
N8,6	8,6	38	3,32	778	855	M816	1600 800 40	40	40	34	40	32	29	23
N10	10	45	3,63	904	980	M819	1900 800 40	52	64	54	64	52	47	39
N12	12	65	4,59	985	1062	M822	2200 800 40	63	93	79	92	75	68	57
N15	15	75	4,75	1023	1100	M825	2500 800 60	75	126	108	125	103	93	78

These tables only give an indication of general capacity and size. Always ask Cavotec Specimas for a specific quotation.

Cable size	mm²	18x 2,5	24x 2,5	4x 16	4x 25	4x 35	3x50 3x10
Outer diameter	~ mm	31	35,6	31,2	37,1	40,3	46,7
Amperage rating	~ Amp	14,4	12,8	83	110	137	170
Weight	~ kg	1,27	1,67	1,47	2,16	2,72	3,4
Drum width F	mm	34	39	34	40	44	51

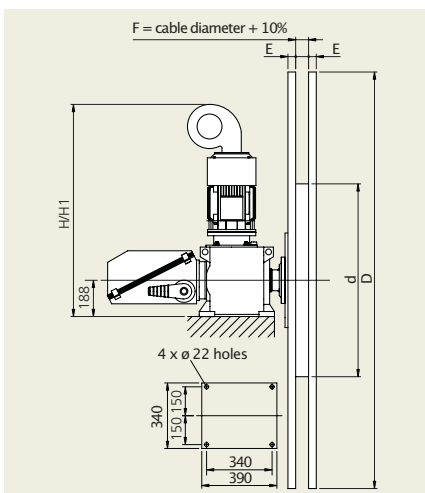

Reducer T5 with torque motor Nominal torque 1200 Nm

Reducer T5				Reel speed (m/min)			Collector 600 V, IP55		
Type	Reduction	Approximate weight (kg)	d=500	d=800	d=1200	Type	K24	K440	K460
T5.0	21	193,0	30	48		N° rings	24	4	4
T5.1	32	207,5	20	32	48	Nominal amperage Amp	30	400	600
T5.2	43	207,5	15	24	36	Continuous rating Amp	20	200	300
T5.3	53	207,5	12	19	28	Weight kg	9	12	35

Torque motors 400V (±5%) - 50 Hz (±400 rpm)						Drum								
Type	Nominal torque Nm	Approx. weight (kg)	Amp	H	H1 ⁽¹⁾	Type	dimension D d E	Approx. weight(kg)	Capacity (metres)					
N5	3	26	1,28	781	853	M514	1400 500 40	28	34	28	24			
N7	5	30	2,72	876	948	M816	1600 800 40	40	40	34	29	23		
N8,6	7	38	3,32	876	948	M819	1900 800 40	52	64	54	47	39	34	
N10	10	45	3,63	876	948	M822	2200 800 40	63	93	79	68	67	51	47
N12	12	65	4,59			M1225	2500 1200 60	136	109	93	81	68	61	57
N15	15	75	4,75			M1228	2800 1200 60	148	147	126	110	93	83	78
						M1231	3100 1200 60	160	189	163	142	120	107	101

These tables only give an indication of general capacity and size. Always ask Cavotec Specimas for a specific quotation.

Cable size	mm²	18x 2,5	24x 2,5	4x 35	3x50 3x10	3x70 3x16	3x95 3x16
Outer diameter	~ mm	30,2	33,6	39	41	49,4	56,4
Amperage rating	~ Amp	14,4	12,8	137	170	210	254
Weight	~ kg	1,27	1,68	2,72	3,4	4,7	6
Drum width F	mm	35	38	44	46	54	60



Cavotec Reel Control (CRC)

CONTINUOUS DUTY

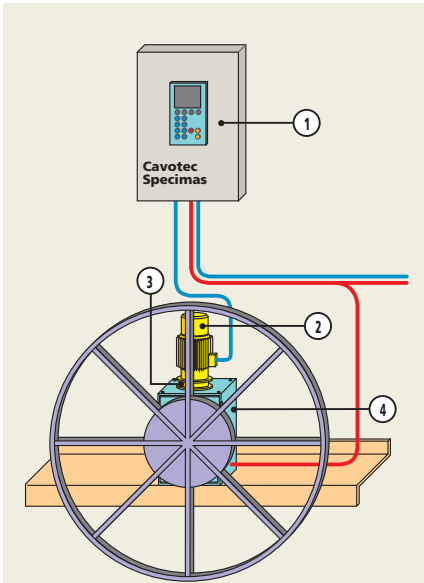

- 1 CRC drive.
- 2 Standard squirrel cage electric motor.
One or more motors can be used in parallel.
- 3 Pre-reducer and holding brake.
- 4 Main gear-box.

The Cavotec Specimas cable reel with CRC drive is the result of a technical cooperation between drive manufacturers and Cavotec Specimas.

The CRC system achieves precise speed and torque control of standard maintenance-free squirrel cage motors. A slipping device between motor and gear-box is not needed.

The Cavotec Specimas CRC driven cable reel allows an almost constant pull on the cable. In fact, by following the torque reference signal (see fig. 1) computed on the basis of reeling variables – such as cable weight, reeled cable on the drum, acceleration or deceleration of the crane, position on the track – the CRC minimizes the pull on the cable.

Cavotec Specimas has also chosen to use oversized, not force ventilated, motors for reliability and for simplicity in system layout. The result is a longer cable life and an increased reliability of the cable reel system.

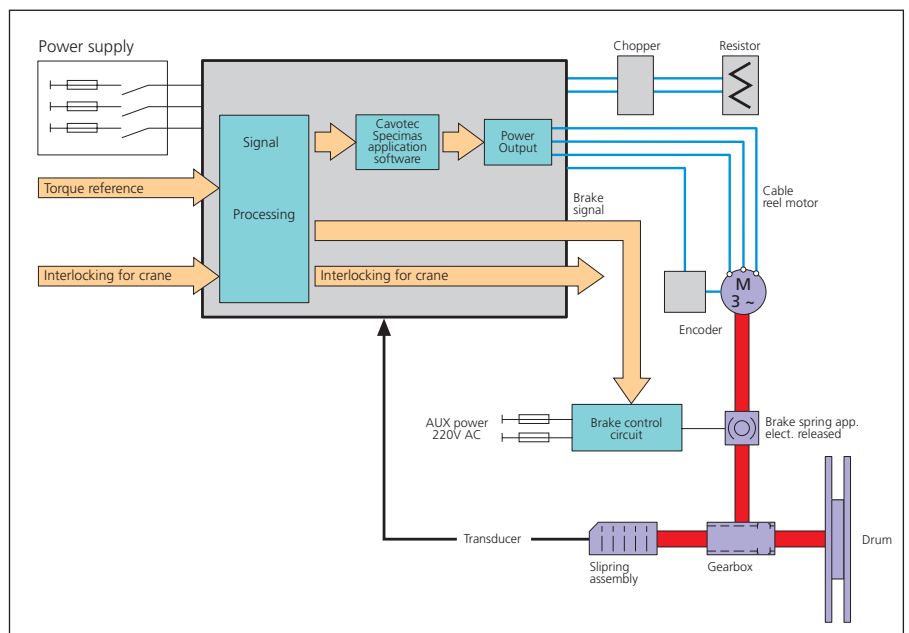
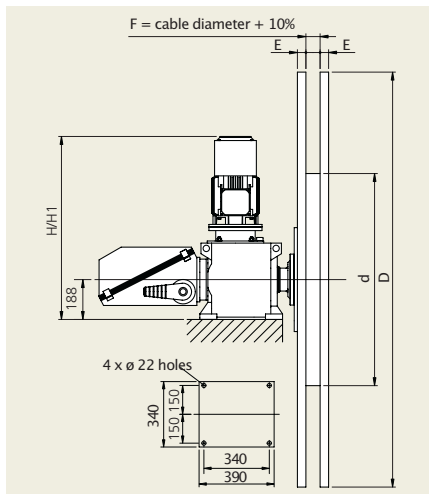

Fig. 1 – Cavotec Reel Control, CRC drive.



Reducer T5 with CRC

Nominal torque 1200 Nm

Reducer T5			Reeling speed (m/min)			Collector 750 V, IP55				
Type	Reduction	Approximate weight (kg)	d=500	d=800	d=1200	Type	K24	K440	K460	
T5.0	21	193,0	104	166	249	N° rings	24	4	4	
T5.1	32	207,5	68	108	162	Nominal amperage Amp	30	400	600	
T5.2	42	207,5	52	83	124	Continuous rating Amp	16	200	300	
T5.3	53	207,5	41	65	97	Weight	kg	9	12	35

Torque motors 400V (±5%) 50Hz (±1400rpm)						Drum				
Motor selection	Nominal torque Nm	Motor weight (kg)	CTC power	CTC output current	H H1 ⁽¹⁾	Type	dimension D d F	Approx. w. (kg)	Capacity (metres)	
1x3kW	20	20			759 831	M514	1400 500 40 20		34 28	24
1x4kW	25	31			773 845	M816	1600 800 40 40		40 34	29 23
2x3kW	2x20	2x20	7,5	18	759 831	M819	1900 800 40 52		64 54	47 39 34
2x4kW	2x25	2x31	11	24	773 845	M822	2200 800 40 63		93 79	68 67 51 47
						M1225	2500 1200 60 136		109 93	81 68 61 57
						M1228	2800 1200 60 148		147 126	110 93 83 78
						M1231	3100 1200 60 160		189 163	142 120 107 101

These tables only give an indication of general capacity and size. Always ask Cavotec Specimas for a specific quotation.

Cable size	mm ²	18x 2,5	24x 2,5	4x 35	3x50 3x10	3x70 3x16	3x95 3x16
Outer diameter	~ mm	30,2	33,6	39	44,9	49,4	56,4
Amperage rating	~ Amp	14,4	18,8	137	170	210	254
Weight	~ kg	1,27	1,68	2,72	3,68	4,70	6,00
Drum width F	mm	35	38	44	50	55	61

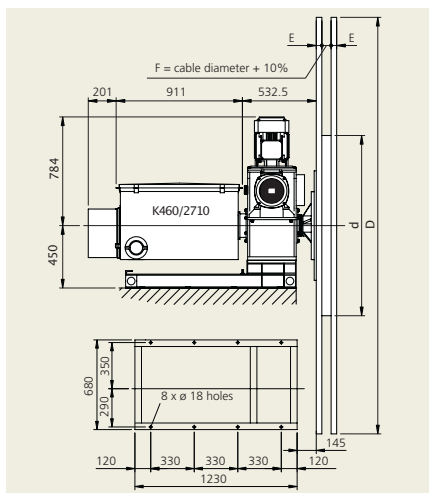

Reducer T6 (600) with CRC

Nominal torque 2500 Nm

Reducer T6			Reeling speed (m/min)			Collector 750 V, IP55				
Type	Reduction	Approximate weight (kg)	d=1500	d=2000	d=2500	Type	K24	K440	K460	
T6.0	33	350	200			Nominal voltage	6	10	15	
T6.1	46	364,5	143	190		Max. voltage	7,2	12	18	
T6.2	57	364,5	115	153	191	N° rings	4	4	4	
						Nominal amperage Amp	600	600	6200	
						Continuous rating Amp	300	300	300	
						Weight	kg	190	210	270
						Shaft height	A	450	450	555

Torque motors 400V (±5%) 50Hz (±1400rpm)						Drum				
Motor selection	Nominal torque Nm	Motor weight (kg)	CTC power	CTC output current	H	Type	dimension D d E	Approx. w. (kg)	Capacity (metres)	
1x7,5kW	50	50	7,5	18	891	M1546	4600 1500 100 530	263 180	247 178	208 189
1x9kW	60	62	11	24	891	M1550	5000 1500 120 640	318 219	299 216	299 216
2x7,5kW	2x50	2x50	15	32	891	M2046	4600 2000 100 530	240 165	225 163	191 173
2x9kW	2x60	2x62	18,5	42	891	M2050	5000 2000 120 650	295 204	278 201	235 214
						M2055	5500 2000 120 820	372 258	350 274	297 270
						M2060	6000 2000 120 1160	456 317	429 312	364 332
						M2560	6000 2500 120 1200	425 296	400 292	340 310

These tables only give an indication of general capacity and size. Always ask Cavotec Specimas for a specific quotation.

Cable size	mm ²	3x35 3x10	3x120 3x25	3x25 3x16	3x95 3x16	3x25 3x10	3x70 3x16
Outer diameter	~ mm	53,2	72,1	56,7	72,5	61,1	72,9
Amperage rating	~ Amp	130	281	105	240	110	210
Weight	~ kg	3,74	8,47	3,9	7,55	4,39	7,08
Drum width F	mm	58	77	61	77	66	77

Cavotec Reel Control (CRC)

CONTINUOUS DUTY

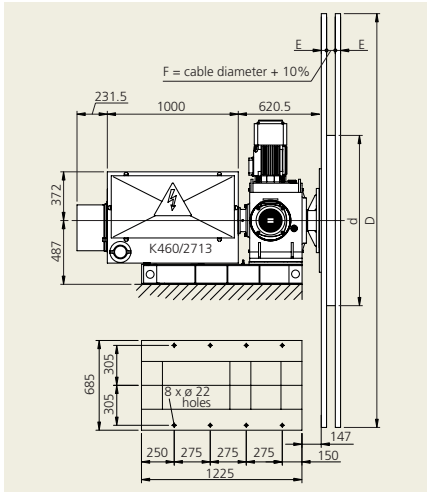

Reducer T7 with CRC

Nominal torque 5000 Nm

Reducer T7			Reeling speed (m/min)			Collector MV, IP55				
Type	Reduction	Approximate weight (kg)	d=1500	d=2000	d=2500	Type	K460/2710	K460/2713	K460/4517	
T7.0	30	450	227			Nominal voltage	kV	6	10	15
T7.1 ⁽¹⁾	45	470	151	202		Max. voltage	kV	7,2	12	18
T7.2 ⁽¹⁾	60	470	113	151	189	N° rings		4	4	4
						Nominal amperage	Amp	600	600	600
						Continuous rating	Amp	300	300	300
						Weight (baseunit included)	kg	190	210	270
						Shaft height	A	450	450	555

Motor 400 V						Drum					
Motor selection	Nominal torque Nm	Motor weight (kg)	DTC power	DTC output current	H H1 ⁽¹⁾	Type	dimension D d E	Approx. w. (kg)	Capacity (metres)		
1x5,5kW	37	40	5,5	15	845 925	M1546	4600 1500 100 530	263 180	247 178	208 189	
1x7,5kW	50	50	7,5	18	845 925	M1550	5000 1500 120 640	318 219	299 216	253 230	
1x9kW	60	62	11	24	845	M2046	4600 2000 100 530	240 165	225 163	191 173	
2x5,5kW	2x37	2x40	11	24	845	M2050	5000 2000 120 650	295 204	278 201	235 214	
						M2055	5500 2000 120 820	372 258	350 254	297 270	
						M2060	6000 2000 120 1160	456 317	429 312	364 332	
						M2560	6000 2500 120 1200	425 296	400 292	340 310	

(1) with pre-reducer

These tables only give an indication of general capacity and size. Always ask Cavotec Specimas for a specific quotation.

Cable size	mm ²	3x35 + 3x10	3x120 + 3x25	3x25 + 3x10	3x95 + 3x16	3x25 + 3x10	3x70 + 3x16
Outer diameter	~ mm	51,3	71,6	54,3	72,6	63,1	68,7
Amperage rating	~ Amp	130	281	105	240	110	210
Weight	~ kg	3,54	8,21	3,38	7,14	4,34	5,56
Drum width F	mm	55	75	58	76	67	72

Reducer T8 with CRC

Nominal torque 7500/12000 Nm

Reducer T8			Reeling speed (m/min)				Collector MV, IP55				
Type	Reduction	Approx. w. (kg)	d=1500	d=2000	d=2500	d=3000	Type	K460/2713	K460/4517	K460/4522	
T8.0	34	950	200				Nominal voltage	kV	10	15	20
T8.1 ⁽¹⁾	51	1000	133	178	223		Max. voltage	kV	12	18	24
T8.2 ⁽¹⁾	68	1000	100	133	167	200	N° rings		4	4	4
							Nominal amperage	Amp	600	600	600
							Continuous rating	Amp	300	300	300
							Weight	Kg	210	270	350
							Shaft height	A	522	600	670

Motor 400 V						Drum					
Motor selection	Nominal torque Nm	Motor weight (kg)	DTC power	DTC output current	H H1 ⁽¹⁾	Type	dimension D d E	Approx. w. (kg)	Capacity (metres)		
1x7,5kW	50	50	7,5	18	920 1005	M1550	5000 1500 120 640	299 216	253 209	233 211	
1x9kW	60	62	11	24	920 1005	M2046	4600 2000 100 530	225 163	191 157	175 159	
2x7,5kW	2x50	2x50	15	32	920	M2050	5000 2000 120 650	278 201	235 194	216 196	
2x9kW	2x60	2x62	18,5	41	920	M2055	5500 2000 120 820	350 254	297 246	273 248	
3x7,5kW	3x50	3x50	22	47	920	M2060	6000 2000 120 1160	429 312	364 302	336 305	
						M2560	6000 2500 120 1200	400 292	340 282	313 285	
						M2573	7300 2500 150 2500	640 468	545 543	503 457	
						M3073	7300 3000 150 2500	604 443	515 429	475 432	

(1) with prereducer

These tables only give an indication of general capacity and size. Always ask Cavotec Specimas for a specific quotation.

Cable size	mm ²	3x25 + 3x10	3x92 + 3x25	3x25 + 3x10	3x70 + 3x16	3x35 + 3x10	3x50 + 3x10
Outer diameter	~ mm	54,3	72,6	63,1	74,8	68	74,2
Amperage rating	~ Amp	105	240	110	210	137	172
Weight	~ kg	3,38	7,14	4,34	5,56	5,44	6,22
Drum width F	mm	58	76	67	78	72	78

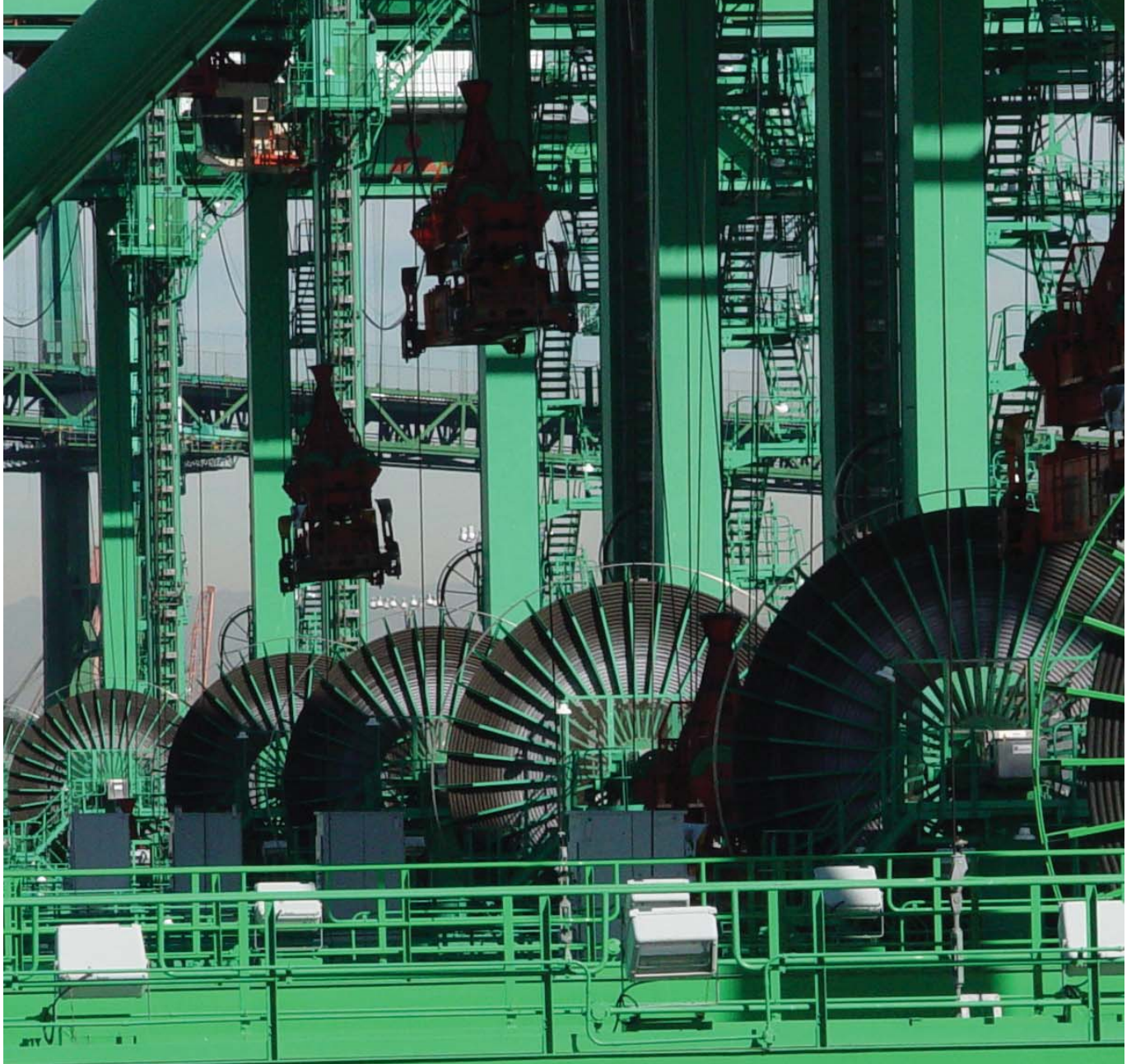

SWL: UNDER SPR
SWL: UNDER CARG



Cavotec Spreader Reels

SPREADER REELS

Container crane spreaders have a requirement for both electrical power and control signals. These are typically supplied via a suspended multi-core electrical cable. This cable has historically been handled by a basket mounted on the spreader headblock. However the basket is not suitable for the higher lifting speeds of modern day cranes; this led to the development of the motorised spreader reel.

Cavotec Specimas spreader reels have been specifically developed for high speed, continuous duty container crane spreader cable applications. They are typically mounted on the trolley, and there are three versions available to accommodate a wide range of space envelopes and application parameters.

For all the spreader reel versions described above, cable tension control is achieved through the use of a CRC drive system. Control systems of varying sophistication are available to accommodate most applications. Spreader reels are typically supplied with a plug and socket to facilitate quick cable replacement. Heavy-duty collectors provide long-term reliability with minimal maintenance requirements.

On the following page we show some examples of possible spreader reel configurations. Please note that these are only examples for illustrational purposes. For exact information please contact Cavotec Specimas or your local Cavotec company.

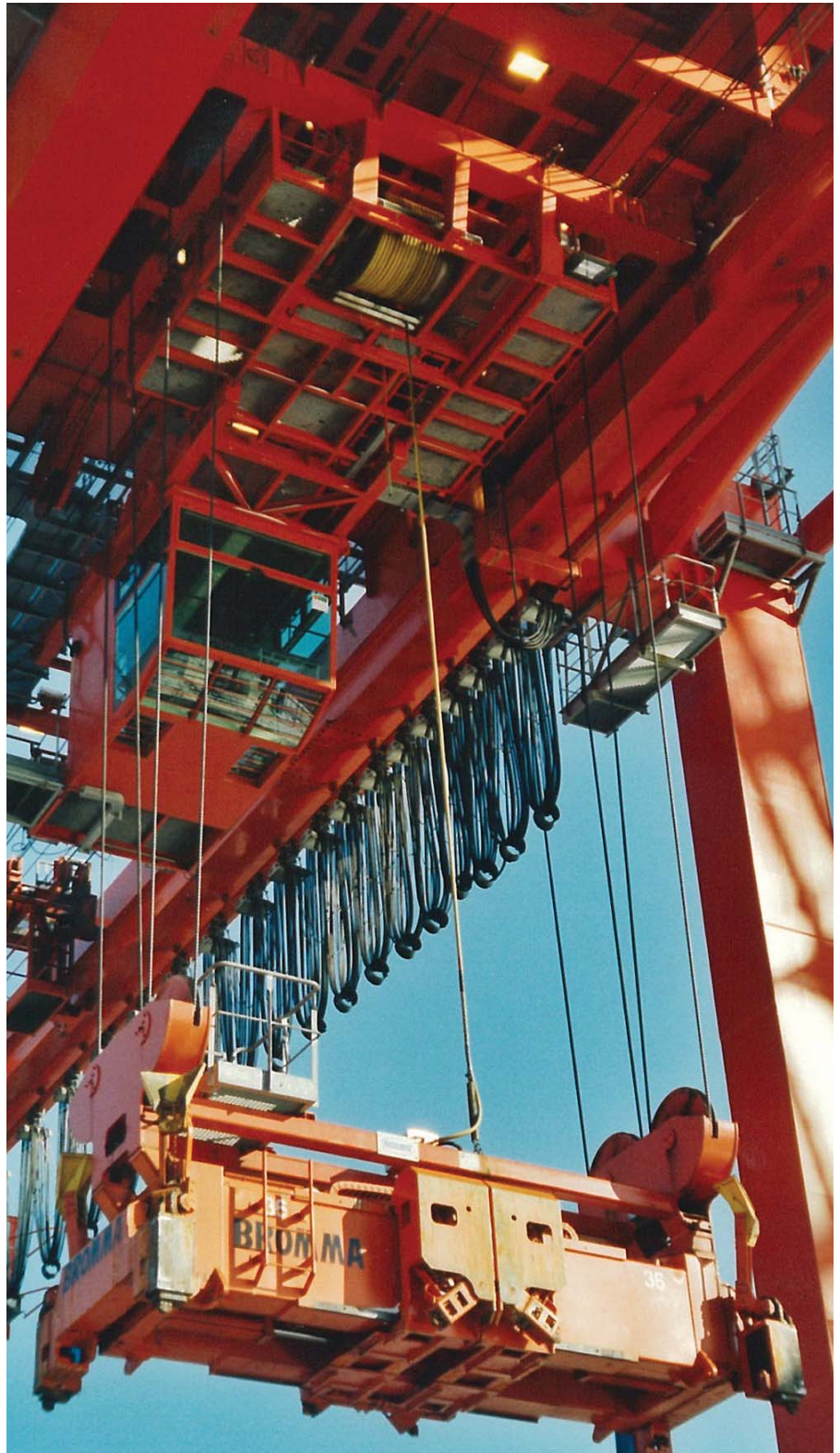

A Cavotec Specimas Spreader Reel in action.

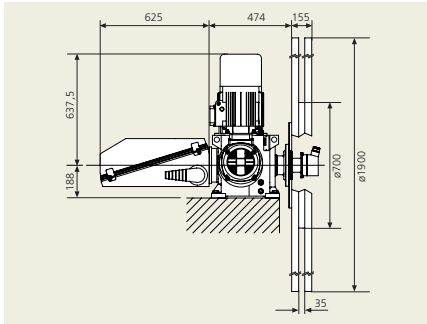

Monospiral Spreader Reel

The Monospiral Spreader Reel is the simplest and most economical version, consisting of a monospiral drum mounted directly onto a reducer as shown in the adjacent figure. Drums can be made from hot-dip galvanised mild steel or stainless steel.

Reel version:	Monospiral
Type code:	T5.0.CRC (2x3kW).6 VM719-35G KV406/32/FCi/R
Cable type:	Gore 42x2.5 mm ²
Cable dimensions:	32.6 mm, 1.7 kg/m
Reeling length:	57 m
Suspended length:	62 m
Spreader speed	150 m/min
Spreader acceleration:	0.63 m/s ²
Drive type:	CRC - Cavotec Reel Control
Control mode:	2 torque levels

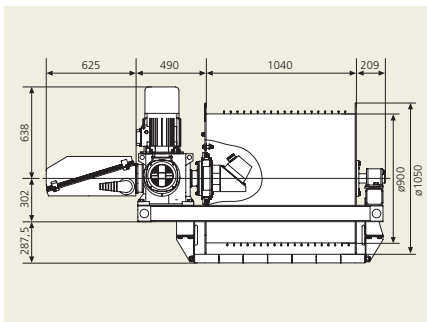

LS Spiralised Spreader Reel

The LS Spiralised Spreader Reel is used when it is not possible to use a monospiral configuration due to height restrictions. A spiral guide reliably lays the cable horizontally on the drum, in a single layer, so there is no need for a sophisticated and potentially troublesome indexing device. LS drums are always made from stainless steel.

Reel version:	LS Spiralised
Type code:	T5.0. CRC (2x5.5kW).4 LS910-1040X KV44/FCi/R
Cable type:	44x2.5 mm ²
Cable dimensions:	37 mm, 2.28 kg/m
Reeling length:	50 m
Suspended length:	55 m
Spreader speed:	180 m/min
Spreader acceleration:	0.75 m/s ²
Drive type:	CRC - Cavotec Reel Control
Control mode:	Linear torque control

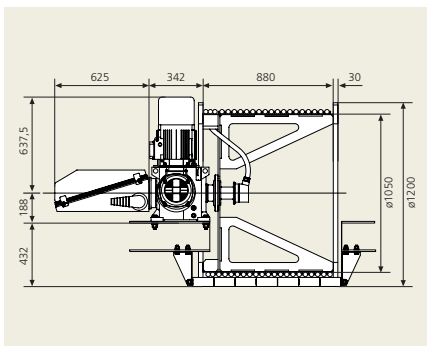

LSC Spiralised Spreader Reel

For applications with lighter cables, the LSC Spiralised Spreader Reel offers a less expensive and more compact alternative to the LS version.

Reel version:	LSC Spiralised
Type code:	T5.2. CRC (2x3kW).4 LSC1012-880X KV406/20/FCi/R
Cable type:	24x2.5 mm ²
Cable dimensions:	29.2 mm, 1.34 kg/m
Reeling length:	57 m
Suspended length:	62 m
Spreader speed:	120 m/min
Spreader acceleration:	1 m/s ²
Drive type:	CRC - Cavotec Reel Control
Control mode:	Linear torque control

The tables on this page only give an indication of general capacity and size. Always ask Cavotec Specimas for a specific quotation.

Main Reel Components

Collectors 600V / 1 kV

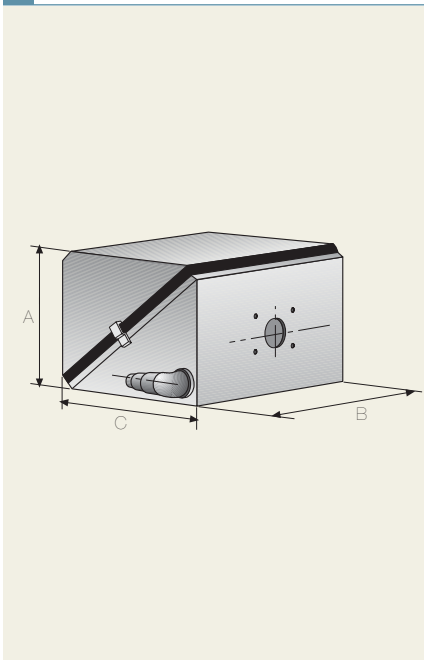

Cavotec Specimas collectors are made as separate sub-components and are interchangeable since the mounting flanges for all torque units and gearboxes are standardised. All collector housings are made in stainless steel and can be opened upwards or sideways due to their diagonal opening.

Standard protection class IP55 but higher grades can also be supplied on request.

All Cavotec Specimas collectors can be fitted with anti-condensation heating elements and with rotary cam limit-switches. Rings are available for nominal amperages of 30, 60, 120, 240, 400, 600, 1200 and 2400 Amps.

Special non-standard ring configurations or combinations with hydraulic swivels or fibre optic rotary joints can be supplied on request.

Type Amperage	Nominal Amperage	Continuous Amperage	Nominal Voltage	Max. cable size (mm)	Dimensions (mm)		
					A	B	C
K 12	30	10	600	2,5	242	370	242
K 24	30	10	600	2,5	271	456	359
K 37	30	10	600	2,5	275	456	461
K 412	120	60	600	25	242	370	242
K 424	240	120	600	35	242	370	242
K 440	400	200	1000	70	272	456	272
K 460	600	300	1000	240	382	642	377
K 4121	1200	600	1000	2 X 240	487	788	480

KP Brush

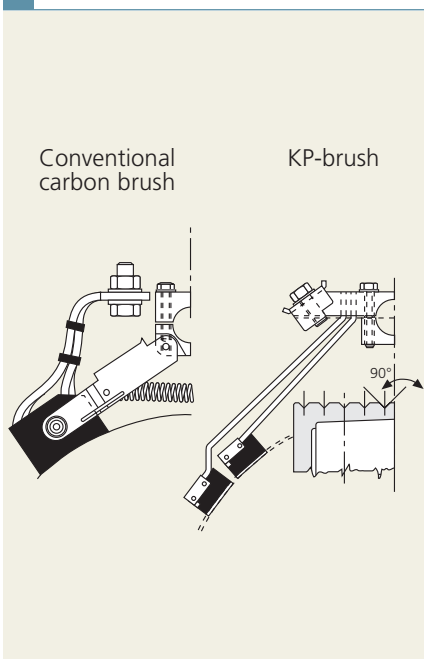

Stand still slipping applications often require a high degree of derating of the current capacity of conventional carbon brushgear. Increasing the physical size of the brushes is not always a solution, since the actual contact area does not increase proportionally.

Cavotec Specimas has overcome this problem by developing a multicontact brushgear which has effectively

drastically increased the capacity. This is achieved by a division of the brush into independent sections, thus ensuring a larger effective contact area.

The diagram shows a comparison between a conventional brushgear (BG) and a multi-contact brushgear (KP) of the same physical size carrying 300 Amp continuous.

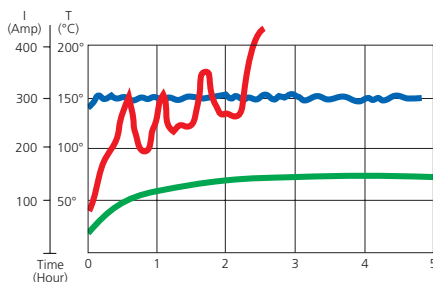

— Continuous current 300 Amp
 — Temperature Carbon brush
 — Temperature Kp-brush

Medium voltage collectors 6, 10, 15, 20 kV

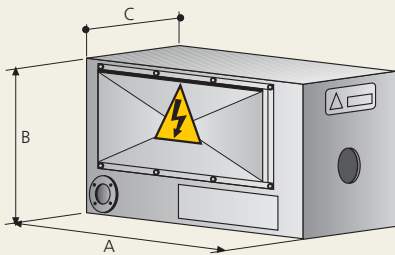

Cavotec Specimas medium voltage collectors are also made as separate sub-components and are all interchangeable since the mounting flange for all torque units and gearboxes are standardised. All collector housings are made out of stainless steel AISI 316.

Standard protection class is IP55 but higher grades can also be supplied on request. All Cavotec Specimas collectors can be fitted with anti-condensation heating elements and

with rotary cam limit-switches.

The collectors can easily be combined with a series of standard fibre optic rotary joints, either accumulator type or prism type for unlimited revolutions. Nominal voltages are 6kV, 10kV, 15kV and 20kV.

Non-standard ring configurations and special interlocking devices can be supplied on request.

Type	Nominal Amperage	Continuous Amperage	Nominal Voltage	Max. voltage	Dimensions (mm)		
					A	B	C
K460/2710 - 6kV	600	300	6000	7200	850	573	730
K460/2713 - 10kV	600	300	10000	12000	1000	697	746
K460/4517 - 15kV	600	300	15000	18000	1100	925	1096
K460/4522 - 20kV	600	300	20000	24000	1450	1110	1200

Swivels

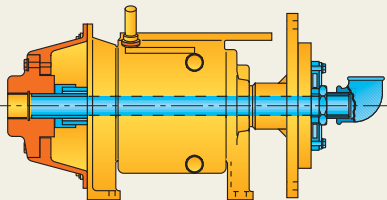

Cavotec Specimas can supply swivels for any fluid for most of the standard torque units and gearboxes. These are made as independent sub-components which can easily be mounted inside the shaft and on the standardised rear mounting flange of the torque units.

All parts are either stainless steel or other non-corrosive material. Standard sizes are 1" and 2".

Working pressure for standard units is 10 bars; swivels for higher pressure and for hose sizes up to 6" are available on request.

Size	Torque unit/ Gear boxes	Max Pressure (bar)	End fittings (Female)
1"	10.0/T3	10	1" Pipe thread
2"	20.0/T4	10	2" Pipe Thread

Main Reel Components

Fibre optic rotary accumulator (GFO)

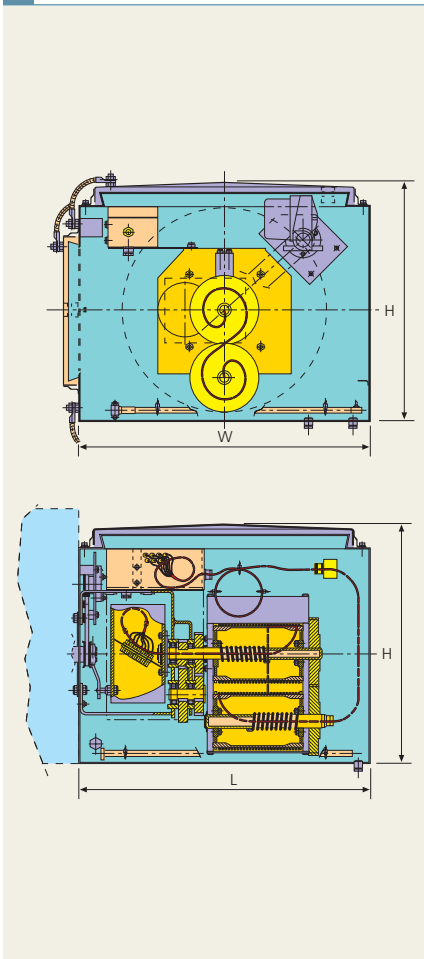

In recent years optical signals are more and more frequently used in ports and terminals. Composite cables including both medium voltage cores and fibre optic bundles are common.

To address these needs, Cavotec Specimas has developed a fibre optic rotary accumulator. The design is heavy-duty and made for rugged environments. The system can also be used as a stand alone rotary accumulator when the reel is equipped with fibre optic cable only.

The housing is made of stainless steel AISI 316 and includes anti-condensation heating element and rotary limit switches.

The signal transmission is uninterrupted, so the only losses are due to the fibres and connectors themselves. With a fibre length of about 15 m in the rotary connector, fibre dimming can be disregarded.

For the rotary accumulator, including bilateral connections, a dimming of less than 3 dB is to be taken into account. The connection is made on both sides via plug connectors in the fixed and rotating terminal boxes.

Terminal strip and coupling bushings are included.

No. turns	No. fibres	L	W	H
40	Up to 12	650	650	530
	Above 12	750	680	653
50	Up to 12	650	650	530
	Above 12	750	680	653
70	Up to 12	750	650	530
	Above 12	850	680	653
110	Up to 12	900	650	530
	Above 12	1000	680	653

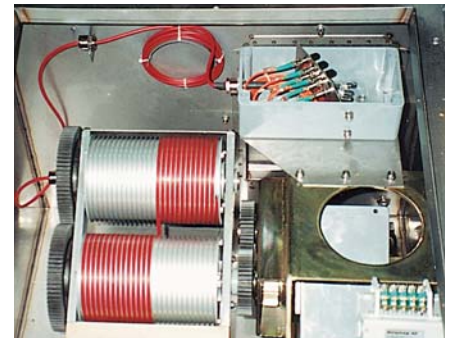

Technical Data

Operational temperature:	-25°C to 60°C
Humidity:	max 90% relative humidity, no surface condensation
Max cable reel drum revolutions:	40/50/70/110
Fibre type:	any commercially available fibre can be fitted
Normally requested fibres are:	single mode 9/125 µm multi mode 50/125 µm multi mode 62,5/125 µm
Standard number of fibres are:	2/4/6/8/10/12/14/18/24
Connectors most commonly used are:	ST-PC with ceramic ferrule or FC-PC with ceramic ferrule. Other type delivered on request

Cable guides



M 1

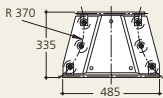

M 3

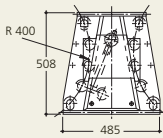

M 5P

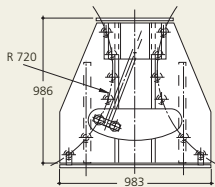

M 7P

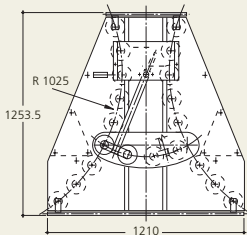

M 9P

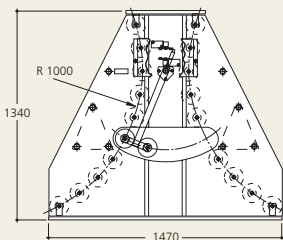

M 10P

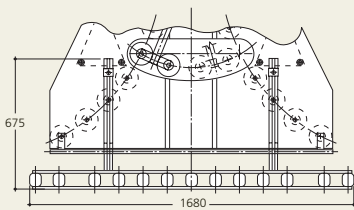

Panzerbelt lifting device

Cable guides are used in horizontal and vertical applications.

In horizontal applications, they are essential in both reeling and unreeling, to ensure that regular laying of the cable is achieved. The cable guide is normally fitted with devices to sense crane location in respect to center feed point (left/right), slack cable and overtension.

In vertical applications it normally depends on the type of drum and its mounting whether a guide is used or not. If the drum is not of a monospiral type (i.e. semi wide or wide), it is recommended to use a guide below the drum to guide the cable centrally onto the drum and to absorb shocks and sway from the cable.

Type	Horizontal application	Vertical application	LV cable ø max mm	MV cable ø max mm	Weight kg
M 1		•	80	80	4
M 3	•		30	25	8
M 5P	•		42	35	20
M 7P	•		76	63	71
M 9P	•		97	89	91
M 10P	•		97	89	105
Panzerbelt lifting device	•		(Optional for M7P, M9P, M10P)		15



Kawasaki Container Terminal Japan.

The Cavotec Specimas Service

Producing high quality products is one matter. Servicing them in such a way that they always perform to the highest standard during their whole life time is quite another. We provide 24/7 hrs assistance for mounting, commissioning, upgrades, repairs and training. Here at Cavotec Specimas we take great pride in the high level performance of our manufactured products. This is why we have a top grade specialised service team to support our customers wherever and whenever this is required. The Cavotec Specimas Service Team operates all over the world through our own sales

companies and distributors located in 30 countries. When you need us, we will be there to help you!

Replacement of a damaged slipping unit on an offshore application in Qatar, at +48 deg. C



A cable reel being commissioned in Korea for a compost plant application.



One of our drums during erection in a harbour application in Singapore.



The commissioning of a giant hose reel for Madrid metropolitan tunnel drilling.



Our service team at minus 30 deg. C in Northern Canada commissioning a CRC reel for a log handling application.



