

- According to IEC/EN 61 812-1
- 8 time ranges from 0.05 s to 300 h selectable via rotational switches
- Impulse and break time separately adjustable
- Selectable start with impulse or break
- Voltage range AC/DC 12 ... 240 V
- Adjustment aid for quick setting of long time values
- Suitable for 2-wire proximity sensor control
- LED indicators for operation, contact position and time delay
- 1 changeover contact
- As option connection of 2 remote potentiometers 10 kΩ
- **Devices available in 2 enclosure versions:**
- **IK 7854:** depth 59 mm, with terminals at the bottom for installation systems and industrial distribution systems according to DIN 43 880
- **SK 7854:** depth 98 mm, with terminals at the top for cabinets with mounting plate and cable duct
- 17,5 mm width

Function diagram

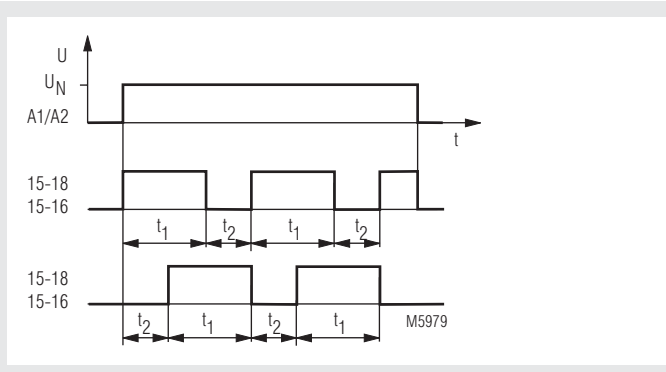

Circuit diagram

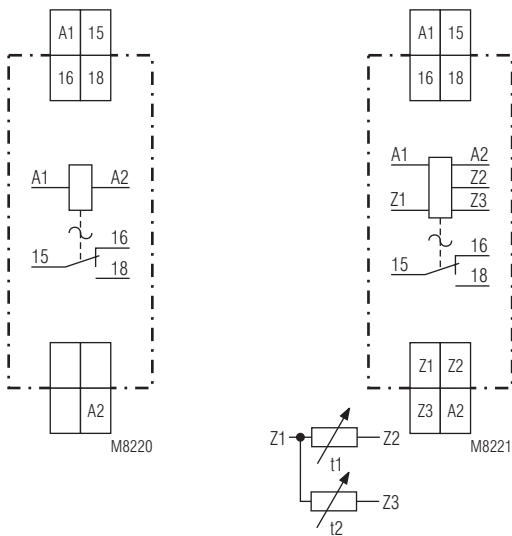

IK 7854.81
SK 7854.81

IK 7854.81/300
SK 7854.81/300

Approvals and marking



Application

Time-dependent controllers

Indicators

- | | |
|--------------------------------|--|
| green LED: | on when voltage connected |
| yellow LED "R/t": | shows status of output relay and time delay: |
| -Flashing (short on, long off) | output relay not active; |
| | time delay t2 (break time) |
| -Flashing (long on, short off) | output relay active; |
| | time delay t1 (pulse time) |

Notes

Control of A1-A2 with proximity sensors

The input can be controlled by DC 3 wire or AC/DC 2 wire proximity sensors. For operating voltage > 24 V and usage of sensors without built-in short circuit protection a protection resistor on A1 is recommended to reduce the inrush current. The dimension is as follows:

$$R_v \approx \text{operating voltage} / \text{max. switching current of sensor}$$

The series resistor must not be selected higher than necessary.

Max. values are:

Operating voltage: 48 V 60 V 110 V 230 V

Series resistor R_v max: 270 Ω 390 Ω 680 Ω 1,8 kΩ (1 W)

Adjustment assistance

The flashing period of the yellow LED is 1 s ± 4% and can be used to adjust the time. Especially on the lower end of scale and for long times it is suitable as the multiplication factors between the different time ranges are exact without tolerance.

Example:

The required time is 40 min. It has to be adjusted within the range 3 ... 300 min. The time check takes too long as several timing cycles would be necessary for a precise value.

For faster adjustment the setting is made to 0.03 ... 3 min. On this range the potentiometer should be set to 0.4 min. (= 24 sec). With the right potentiometer setting the LED must show 24 flashing cycles. After that the time range is switched over to 3 ... 300 min and the setting is complete.

Notes

Remote potentiometers

With the variant IK/SK 7854.81/300 both time settings can also be made via remote potentiometers of 10 kOhms:

- Terminals Z1-Z2: potentiometer for pulse time (t₁)
- Terminals Z1-Z3: potentiometer for break time (t₂)

When connecting a remote potentiometer, the corresponding potentiometer has to be set to min. If no remote potentiometers are required the terminals Z1-Z2 resp. Z2-Z3 have to be linked.

The wires to the remote potentiometers should be installed separately from the lines with mains voltage. If this is not possible, a screened cable is recommended where the shield is connected to Z1.

To terminals Z1, Z2 and Z3 no external voltage must be connected, as the unit might be damaged.

Setting

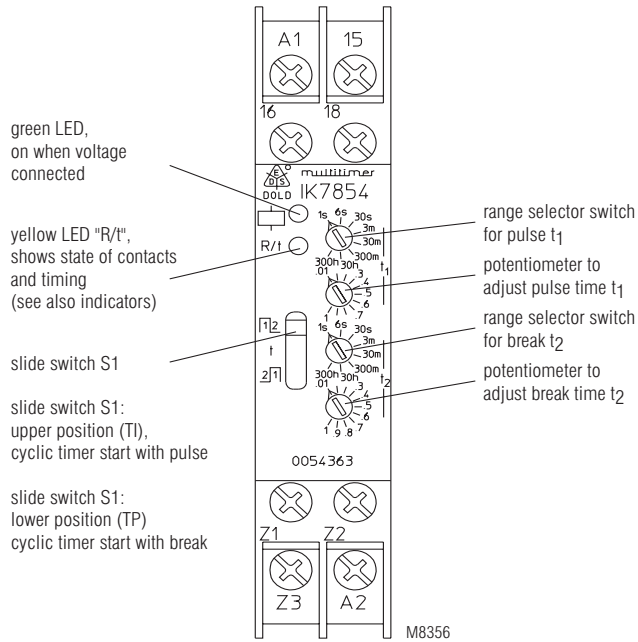

Technical data

Time circuit

Time ranges:	8 time ranges for pulse and break time, settable via rotational switch:	
	0,05 ... 1 s	0,3 ... 30 min.
	0,06 ... 6 s	3 ... 300 min.
	0,3 ... 30 s	0,3 ... 30 h
	0,03 ... 3 min.	3 ... 300 h
Time setting t₁, t₂:	continuous, 1:100 on relative scale	

Recovery time:

at DC 24 V:	approx. 15 ms
at DC 240 V:	approx. 50 ms
at AC 230 V:	approx. 80 ms
Repeat accuracy:	± 0,5 % of selected end scale value

Voltage and

Temperature influence:	< 1 % with the complete operating range
-------------------------------	---

Input

Nominal voltage U_N:	AC/DC 12 ... 240 V
Voltage range:	0,8 ... 1,1 U _N
Frequency range (AC):	45 ... 400 Hz
Nominal consumption	
at AC 12 V:	approx. 1,5 VA
at AC 24 V:	approx. 2 VA
at AC 230 V:	approx. 3 VA
at DC 12 V:	approx. 1 W
at DC 24 V:	approx. 1 W
at DC 230 V:	approx. 1 W

Technical data

Release voltage (A1/A2)

AC 50 Hz:	approx. 7,5 V
DC:	approx. 7 V

Max. permitted residual current with 2-wire proximity sensor control (A1-A2)

up to AC/DC 150 V:	AC resp. DC 5 mA
up to AC/DC 264 V:	AC resp. DC 3 mA

Output

Contacts:

IK/SK 7854.81:	1 changeover contact
Thermal current I_{th}:	4 A

Switching capacity

to AC 15		
NO contact:	3 A / AC 230 V	IEC/EN 60 947-5-1
NC contact:	1 A / AC 230 V	IEC/EN 60 947-5-1
to DC 13:	1 A / DC 24 V	

Electrical life

at AC 15 to 1 A, AC 230 V:	1,5 x 10 ⁵ switching cycles	IEC/EN 60 947-5-1
----------------------------	--	-------------------

Permissible switching frequency:

	36 000 switching cycles / h
--	-----------------------------

Short circuit strength

max. fuse rating:	4 A gL	IEC/EN 60 947-5-1
--------------------------	--------	-------------------

Mechanical life:

	30 x 10 ⁶ switching cycles
--	---------------------------------------

General data

Operating mode:

Continuous operation

Temperature range:

- 40 ... + 60°C

Clearance and creepage distances

overvoltage category / contamination level:	4 kV / 2	IEC 60 664-1
---	----------	--------------

EMC

Electrostatic discharge:	8 kV (air)	IEC/EN 61 000-4-2
Fast transients:	2 kV	IEC/EN 61 000-4-4

Surge voltages between

wires for power supply:	1 kV	IEC/EN 61 000-4-5
HF-wire guided:	10 V	IEC/EN 61 000-4-6

Degree of protection:

Housing:	IP 40	IEC/EN 60 529
Terminals:	IP 20	IEC/EN 60 529

Housing:

Thermoplastic with V0 behaviour according to UL subject 94
Vibration resistance: Amplitude 0,35 mm, frequency 10 ... 55 Hz, IEC/EN 60 068-2-6
 40 / 060 / 04 IEC/EN 60 068-1

Climate resistance:

Terminal designation:

Wire connection:

EN 50 005
 2 x 2,5 mm² solid or 2 x 1,5 mm² stranded wire with sleeve
 DIN 46 228-1/-2/-3/-4
Wire fixing: Flat terminals with self-lifting clamping piece IEC/EN 60 999-1
 DIN rail IEC/EN 60 715

Mounting:

Weight:

IK 7854:	approx. 65 g
SK 7854:	approx. 84 g

Dimensions

Width x height x depth:

IK 7854:	17,5 x 90 x 59 mm
SK 7854:	17,5 x 90 x 98 mm

Standard type

IK 7854.81 AC/DC 12 ... 240 V 0,05 s ... 300 h

- Article number: 0054362
- Output: 1 changeover contact
 - Nominal voltage U_N : AC/DC 12 ... 240 V
 - Time ranges: 0,05 s ... 300 h
 - Width: 17,5 mm

SK 7854.81 AC/DC 12 ... 240 V 0,05 s ... 300 h

- Article number:
- Output: 1 changeover contact
 - Nominal voltage U_N : AC/DC 12 ... 240 V
 - Time ranges: 0,05 s ... 300 h
 - Width: 17,5 mm

Variants

- IK 7854.81/300: - Connection facility for 2 remote potentiometers 10 kOhms to adjust pulse and break time

Ordering example for variants

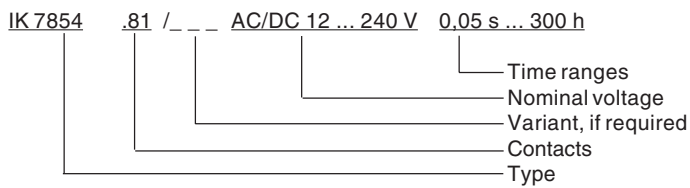

Accessories

- AD 3: External potentiometer 10 k Ω

The external potentiometer is used for remote setting of the time delay. The internal potentiometer of the timer must be set to min. time delay.

Degree of protection front side:

IP 60

