

Block diagram

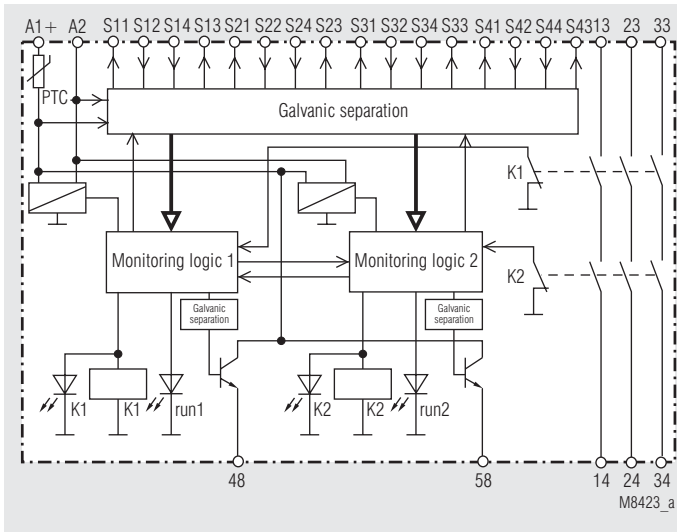

Table of contents

Content	page
Features, Indication, Notes	1
Setting table	2
Operating modes, Manual and Auto start	3
Functions:	
E-stop	4
Light curtains	6
Light curtains + E-stop	7
Gate monitor	9
Gate monitor + E-stop	12
2-Hand-Safety	14
2-Hand-Safety + E-stop	16
Circuit diagrams, Technical data	18
Standard type, Example of order, Flash codes for fault indication	19

- According to EU directive for machines 98/37/EG
- According to IEC/EN 60 204, IEC/EN 61 496-1
- Safety category 4 according to EN 954-1
- Functions selectable via rotational switches to connect max.:
 - 8 E-stop circuits, single channel or
 - 4 E-stop circuits, 2-channel or
 - 4 light curtains or
 - 2 light curtains and 1 E-stop circuit or
 - 4 safety gates or
 - 2 safety gates and 1 E-stop circuit or
 - 4 pairs of 2-hand-buttons or Typ III A according to DIN EN 547 or
 - 2 pairs of 2-hand-buttons Typ III C according to DIN EN 547 and 1 E-stop circuit
- In addition selectable:
 - auto or manual reset (simulation input for gate monitor)
 - continuously monitored feedback circuit to monitor external contactors
- Cross fault detection
- Short circuit and broken wire detection
- Outputs:
 - 3 NO or 2 NO and 1 NC contacts
 - 2 semiconductor outputs short circuit proof and overload protected
- Under- and overvoltage detection and signalling
- LED indication for operation (RUN), channel 1/2
- 45 mm width

Approvals and marking



* see variants

Applications

- Protection of men and machines

Indication

lower green LEDs K1, K2:	On, when relays K1 and K2 are energised
upper yellow LEDs run 1, run 2:	Continuously on on fault free operation. Regular flashing when waiting for external action e.g. release of an E-stop button. Detected faults are indicated with special flashing sequences (see flash codes for fault indication)
Terminal 48:	Flashes, as long as starting condition is not fulfilled.
Terminal 58:	Flashes while waiting for start or simulation input (button). Continuous signal when relay enabled.

Notes

- On BH 5910.22 the NC contact 31 - 32 can only be used as monitoring contact.
- Changes of settings are only permitted when supply voltage is disconnected and have to be made by trained persons only.
- Before removing the front cover please touch ground potential.

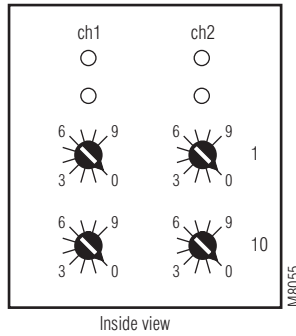
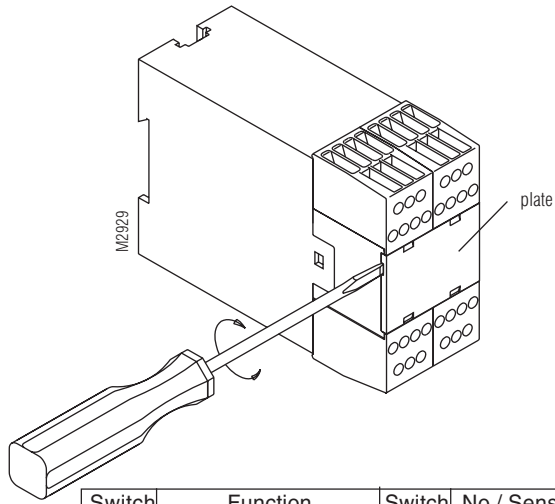

The selection of the function of BH 5910 is done via 4 rotational switches behind the front cover of the unit (see drawing on the left). The 2 switches on the left set processor 1 (ch 1) and the 2 switches on the right set processor 2 (ch 2). Both processors must have the same setting. On both upper switches (1) the function is selected, on both lower switches (10) the number of sensor circuits, control and operation mode and the feedback circuit option is selected.

Switch 1	Function	Switch 10	No / Sensors	Control mode	Operation mode	Feedback circuit for external contacts
0	E-stop	0	4	2-channel	auto start	no
		1	3	2-channel	manual start	no
		2	8	single channel	auto start	no
		3	6	single channel	manual start	no
		4	3	2-channel	auto start	yes
		5	3	2-channel	manual start	yes
		6	6	single channel	auto start	yes
1	Light curtains (LC)	0	4	2-channel	auto start	no
		1	3	2-channel	manual start	no
		2	3	2-channel	auto start	yes
		3	3	2-channel	manual start	yes
2	Light curtains + E-stop, (1 E-stop button, 2-channel, manual start)	0	2	2-channel	auto start	no
		1	2	2-channel	manual start	no
		2	2	2-channel	auto start	yes
		3	2	2-channel	manual start	yes
3	Gate monitor	0	4	2 NO contacts	without simulation button	no
		1	3	2 NO contacts	with simulation button	no
		2	2	2 C/O contacts	without simulation button	no
		3	1	2 C/O contacts	with simulation button	no
		4	2	3 NO contacts	with simulation button	no
		5	1	2 C/O, 1 NO contacts	with simulation button	no
		6	3	2 NO contacts	with simulation button	yes
		7	1	2 C/O contacts	with simulation button	yes
		8	2	3 NO contact	with simulation button	yes
4	Gate monitor + E-stop, (1 E-stop button, 2-channel, manual start)	0	2	2 NO contacts	with simulation button	no
		1	1	2 C/O contacts	with simulation button	no
		2	1	3 NO contacts	with simulation button	no
		3	2	2 NO contacts	with simulation button	yes
		4	1	2 C/O contacts	with simulation button	yes
5	2-hand safety	0	1	2 NO contacts		no
		1	2	2 NO contacts		no
		2	3	2 NO contacts		no
		3	4	2 NO contacts		no
		4	1	2 C/O contacts		no
		5	2	2 C/O contacts		no
		6	1	2 NO contacts		yes
		7	2	2 NO contacts		yes
		8	3	2 NO contacts		yes
6	2-hand safety + E-stop (1 E-stop button, 2-channel, manual start)	0	1	2 NO contacts		no
		1	2	2 NO contacts		no
		2	1	2 C/O contacts		no
		3	1	2 NO contacts		yes
		4	2	2 NO contacts		yes
7	not permitted	0	1	2 C/O contacts		yes
		1	2			
		2	1			
		3	1			
		4	2			
8	not permitted	0	1			
		1	2			
		2	1			
		3	1			
		4	2			

Operating mode

• Auto start

(with function E-stop and light curtain)

On automatic restart the output contacts are activated when the input condition for the selected function is fulfilled.

A start-button is only necessary in 2 cases:

- If the function light curtain, safety gate or 2-hand-safety is combined with E-stop.
- If a function with feedback circuit is selected and the unit has to be reset after a detected fault without disconnection.

• Manual start

(with function E-stop and light curtain)

If the unit was deactivated by operating the safety function e.g. by pressing an e-stop button it only can be reset in manual mode by pressing the start button. After voltage failure the unit has to be reset also with the start button. The button has to be pressed not longer then 3 sec. to allow the unit to energise.

If one of the functions light curtain, safety gate or 2-hand-safety is combined with E-stop the E-stop function always works with manual restart.

When manual start is selected, the start button is always connected to terminals S43-S44.

Feedback circuit to monitor external contactors

If the number of contacts has to be increased or a higher current has to be switched by contactors a feedback circuit with NC contactors can be connected to terminals S41-S42 (see drawing 1). This circuit allows to monitor the state of the external contactors. The BH 5910 monitors continuously if the state of this input corresponds to the state of K1 and K2.

In the case of a fault K1 and K2 switch off or do not switch on at all. If the fault is removed, the BH 5910 has to be reset with the start button.

When operating the unit with feedback circuit the circuit has to be connected to terminal S41 and S42.

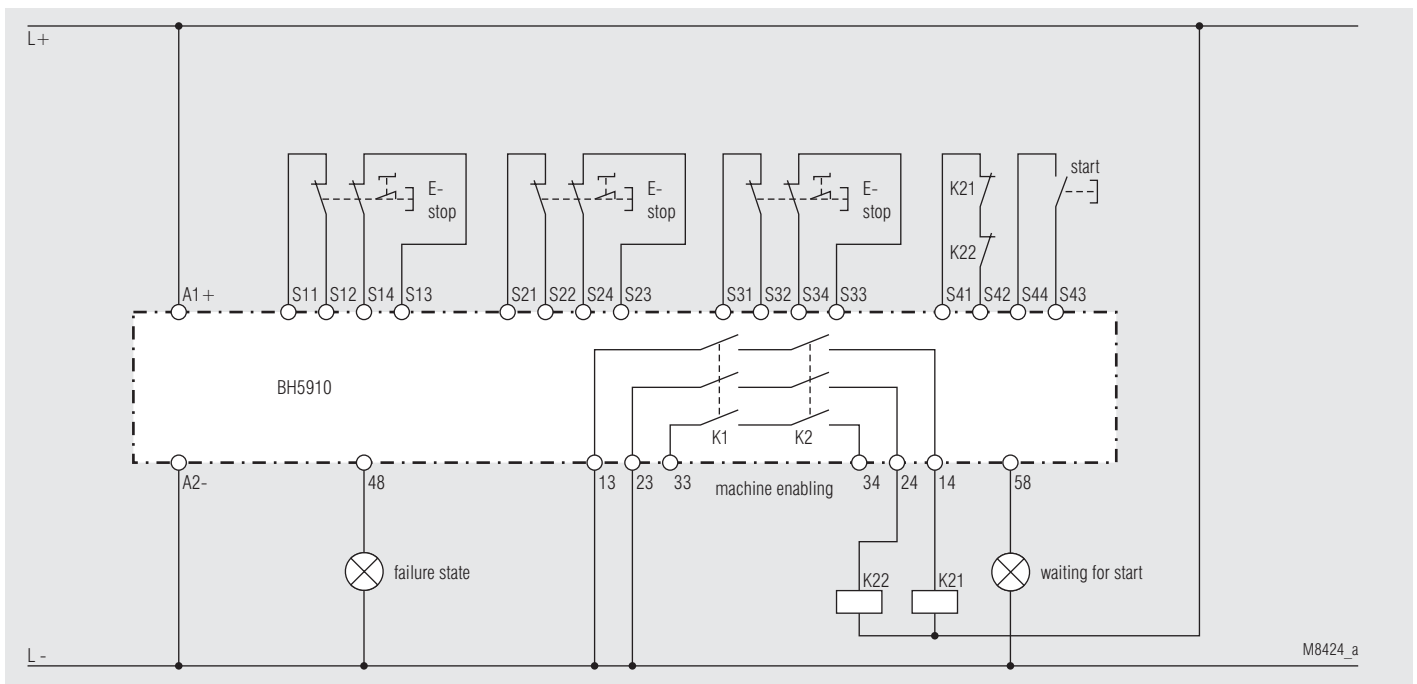

Pic. 1: E-stop, 2-channel, with 3 E-stop buttons, manual start and 2 external contactors with feed back circuits
(Switch 1: position 0, switch 10: position 4 or 5)

E-stop (switch 1 in position 0)

With switch 10 the maximum number of e-stop loops is selected. Open (unused) inputs (S_1/S_2 and S_3/S_4) have to be linked with a wire bridge.

K1 and K2 can only be activated, if all e-stop buttons are released. The function diagrams show only the action of one e-stop button. We pretend that the others are closed.

When the unit is used with 2-channel e-stop loops, it checks the state of the inputs. If both channels have different signals for more than 50 ms the outputs K1 and K2 are switched off and the unit gives failure code 7. This failure is stored and can only be reset by disconnecting the auxiliary supply.

Settings on switch 10

Switch 10	Number of E-stop loops	Type of control	Type of start	Feedback circuit for external contactors
0	4	2-channel	auto start	no
1	3	2-channel	manual start	no
2	8	1-channel	auto start	no
3	6	1-channel	manual start	no
4	3	2-channel	auto start	yes
5	3	2-channel	manual start	yes
6	6	1-channel	auto start	yes
7	6	1-channel	manual start	yes
8	position not allowed (failure code 5)			
9	position not allowed (failure code 5)			

Function diagrams

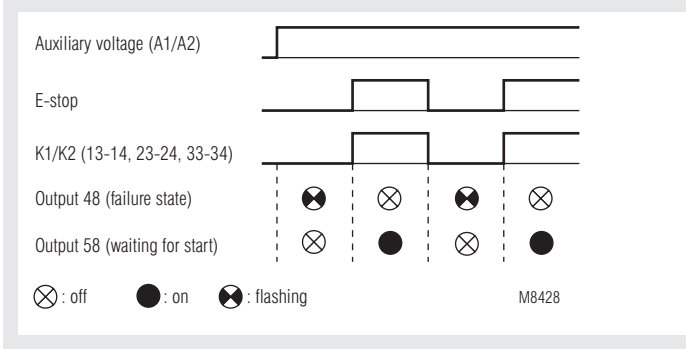

E-stop, 2-channel, auto start

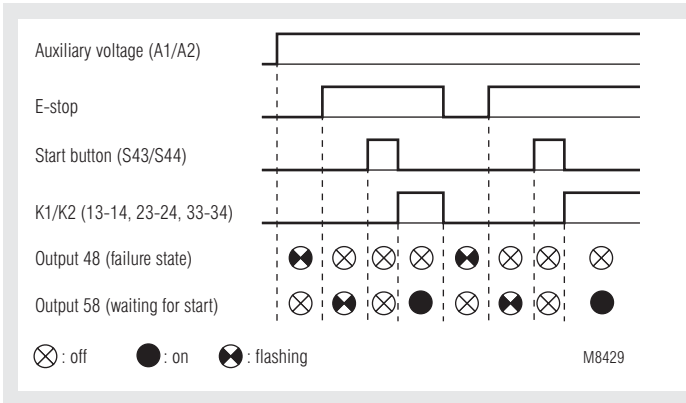

E-stop, 2-channel, manual start

Terminal designation

Terminal	E-stop loop, 1-channel	E-stop loop, 2-channel	feedback circuit and/or manual start
S11 S12	E-stop 1	E-stop 1	
S13 S14	E-stop 2		
S21 S22	E-stop 3	E-stop 2	
S23 S24	E-stop 4		
S31 S32	E-stop 5	E-stop 3	
S33 S34	E-stop 6		
S41	E-stop 7	E-stop 4	Feedback circuit or no connection
S42			start button
S43			
S44	E-stop 8		

Semiconductor outputs

Output	Flashing signal	Continuous signal
48	E-stop active or failure in feedback circuit or failure on start button	
58	Wait for start button	Relay K1, K2 active

Application example

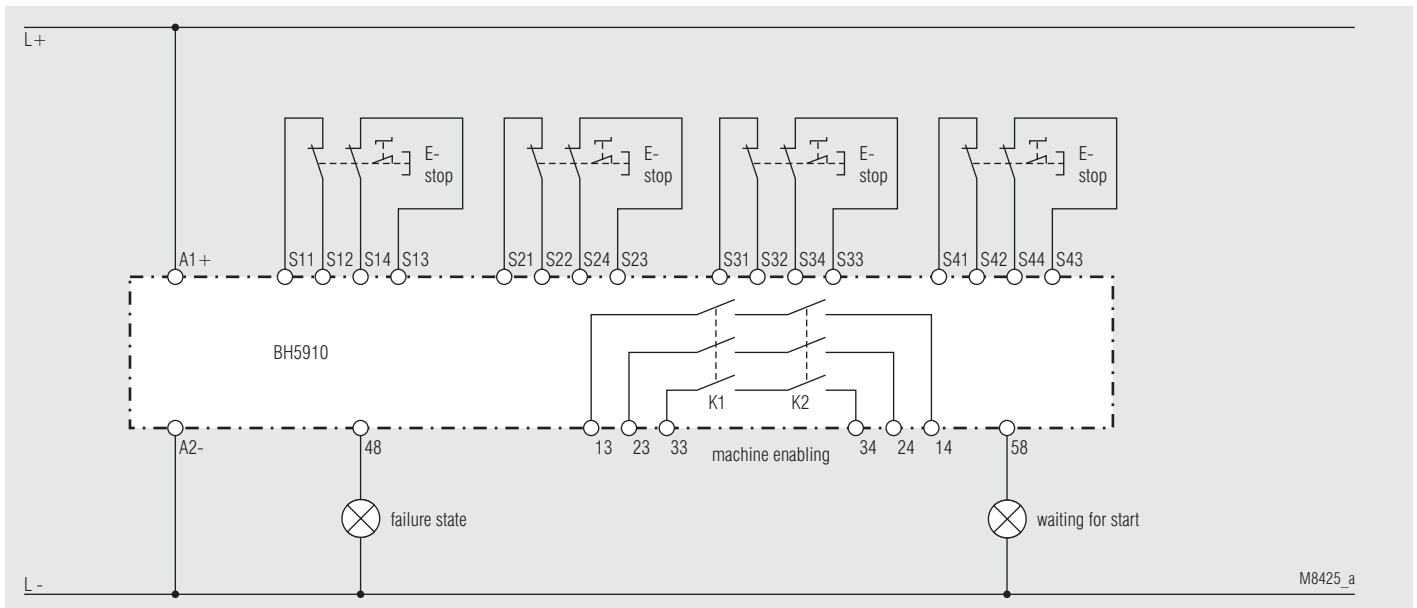

Pic. 2: E-stop, 2-channel, with 4 e-stop loops, auto start (switch 1 in position 0, switch 10 in position 0)

E-stop, application examples

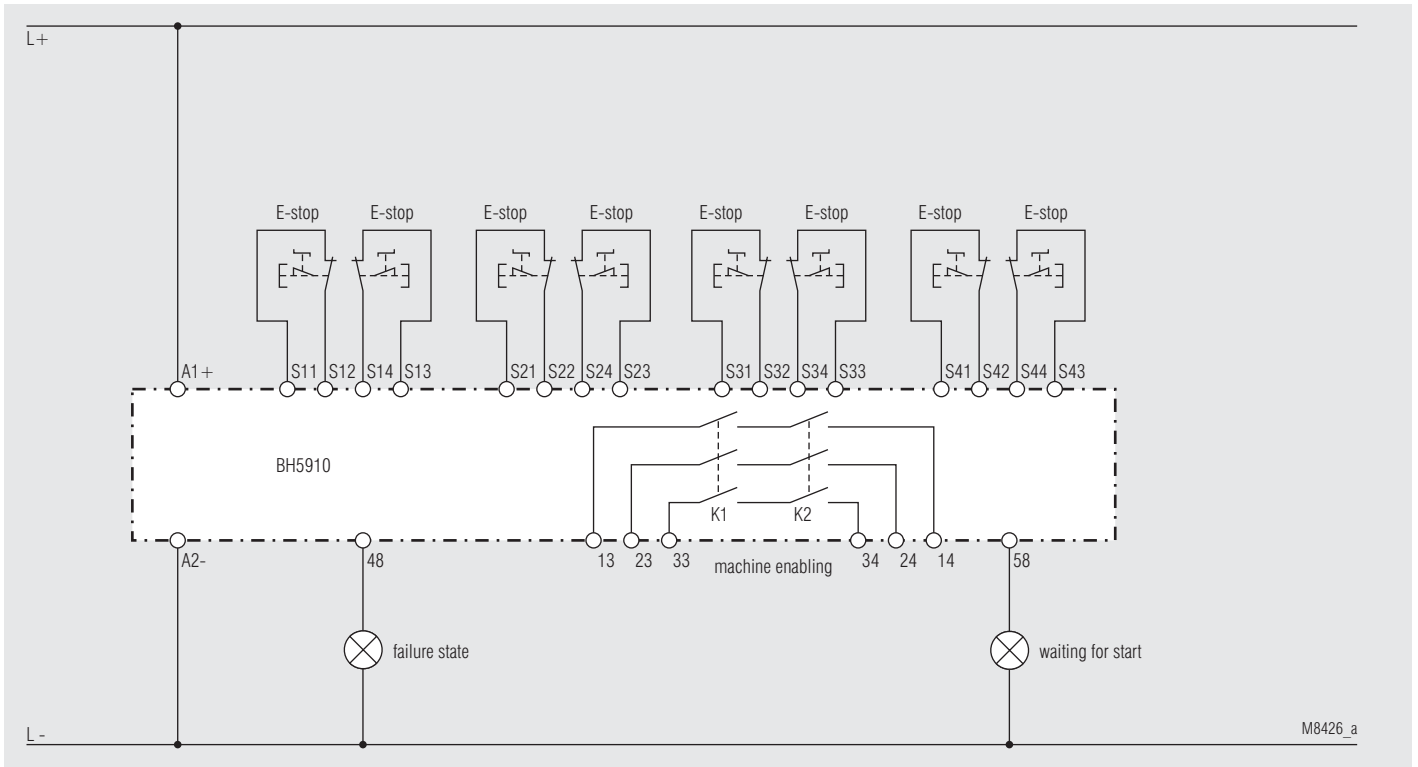

Pic. 3: E-stop, 1-channel, with 8 e-stop loops, auto start; (switch 1 in position 0, switch 10 in position 2)

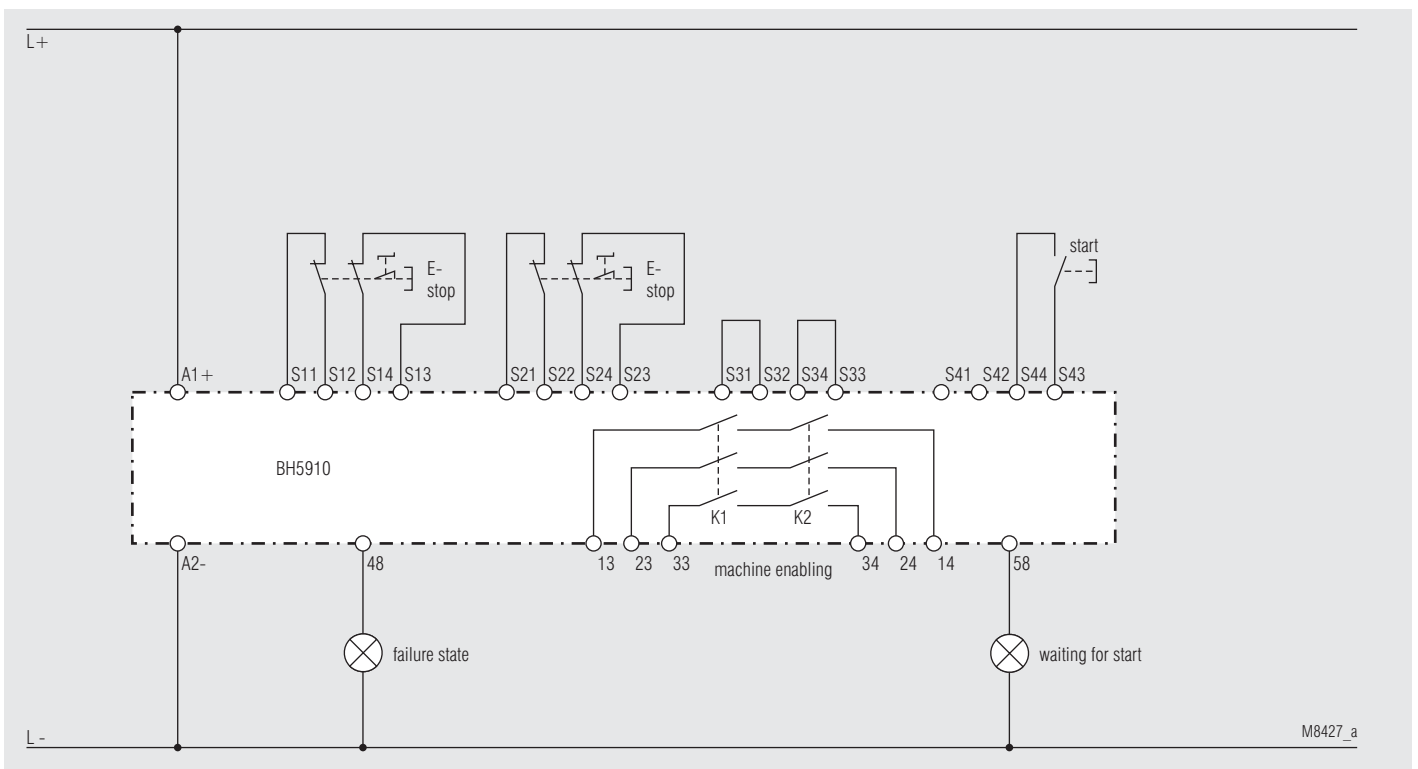

Pic. 4: E-stop, 2-channel, with 2 e-stop loops, manual start; (switch 1 in position 0; switch 10 in position 1)

Light curtains (switch 1 in position 1)

With switch 10 the maximum number of LCs (Light curtains) is selected. Open (unused) inputs (S_1/S_2 and S_3/S_4) have to be linked with a wire bridge.

K1 and K2 can only be activated, if no LC is interrupted.

If both channels of an LC have different signals for more than 50 ms the outputs K1 and K2 are switched off and the unit gives failure code 7. This failure is stored and can only be reset by disconnecting the auxiliary supply. The BH 5910 can be used on LCs of type 4 (IEC/EN 61 496-1) or type 2 with self test and crossfault monitoring.

The following function diagrams show the function of one LC. We pretend that other connected LCs are not interrupted.

Settings on switch 10

Switch 10	No. of LCs	Type of control	Type of start	Feedback circuit for external contactors
0	4	2-channel light curtains	auto start	no
1	3	2-channel light curtains	manual start	no
2	3	2-channel light curtains	auto start	yes
3	3	2-channel light curtains	manual start	yes
4-9	position not allowed (failure 5)			

Terminal designation

Terminal	Light curtains	Feedback circuit and/or manual start	
S11	not connected	link S11-S12 without LC1	
S12	LC 1		
S13	not connected		link S13-S14 without LC1
S14	LC 1		
S21	not connected	link S21-S22 without LC2	
S22	LC 2		
S23	not connected		link S23-S24 without LC2
S24	LC 2		
S31	not connected	link S31-S32 without LC3	
S32	LC 3		
S33	not connected		link S33-S34 without LC3
S34	LC 3		
S41	not connected	link S41-S42 without LC4	Feedback circuit or no connection
S42	LC 4		
S43	not connected	link S43-S44 without LC4	start button
S44	LC 4		

Semiconductor outputs

Output	Flashing signal	Continuous signal
48	One LC interrupted or failure in feedback circuit or in start circuit	
58	Wait for start button	Relay K1, K2 active

Function diagrams

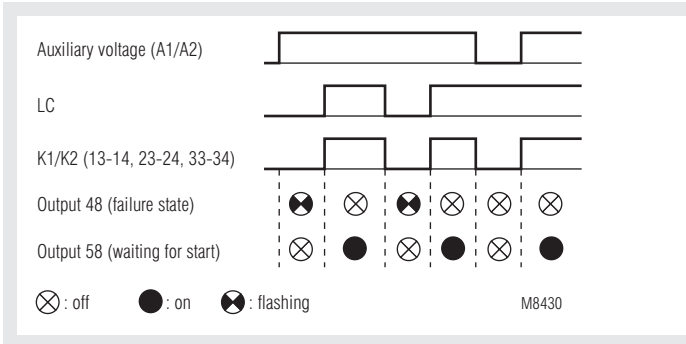

Light curtains, auto start

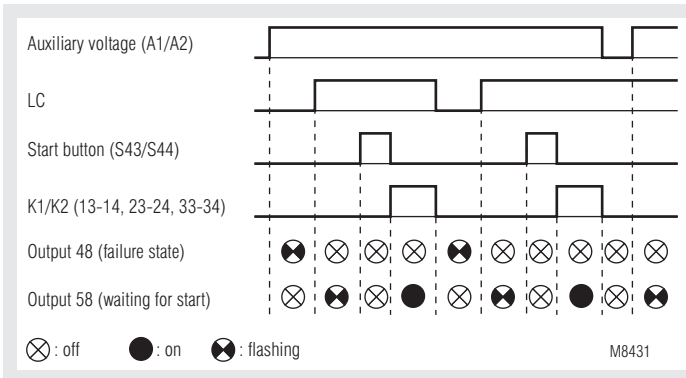

Light curtains, manual start

Application example

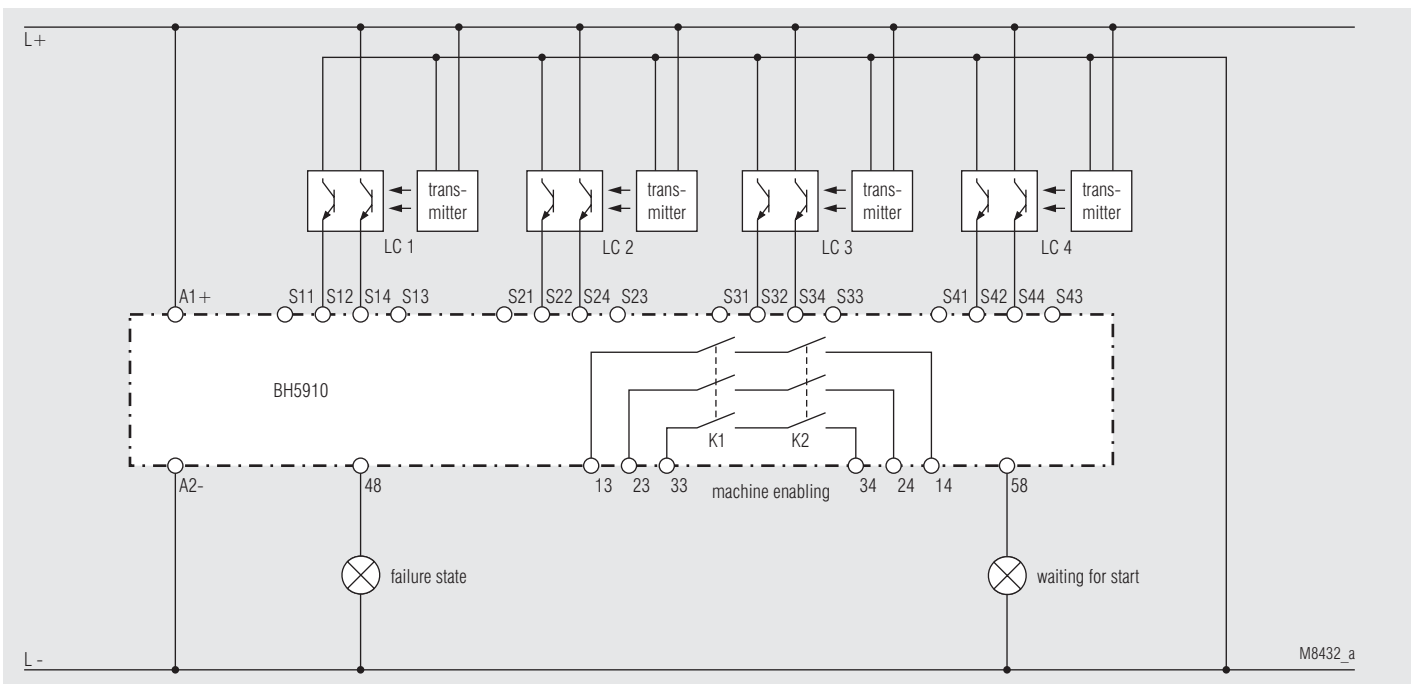

Pic. 5: Light curtains, with 4 LCs, auto start; (switch 1 in position 1, switch 10 in position 0)

Light curtains (switch 1 in position 1); Application example

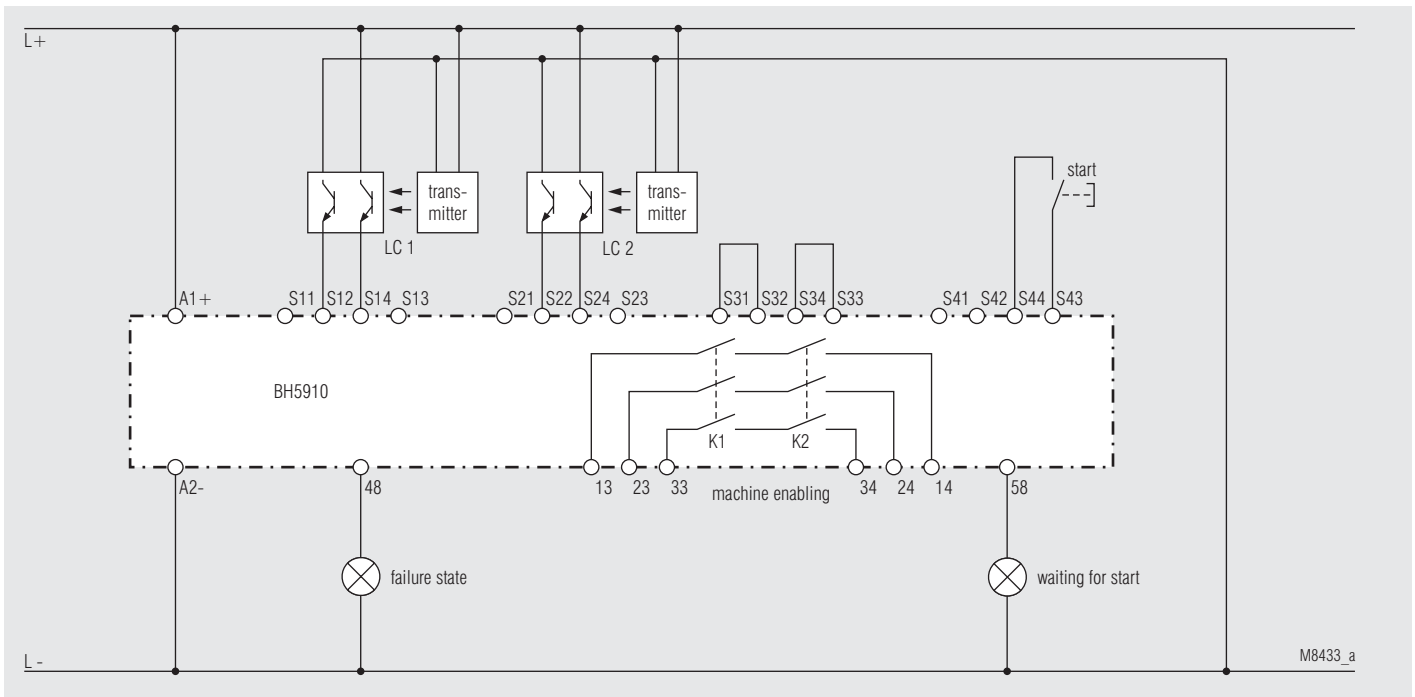

Pic. 6: Light curtains, with 2 LCs, manual start; (switch 1 in position 1, switch 10 in position 1)

Light curtains and E-stop (switch 1 in position 2)

In this function the unit is always set to 2 LCs and 1 e-stop loop. Open (unused) inputs (S21/S22 and S23/S24) have to be linked with a wire bridge.

K1 and K2 can only be activated, if no LC is interrupted and the e-stop loop is closed.

After an e-stop or power failure the unit has to be reset with manual start. If both channels of an LC or e-stop loop have different signals for more than 50 ms the outputs K1 and K2 are switched off and the unit gives failure code 7. This failure is stored and can only be reset by disconnecting the auxiliary supply.

Settings on switch 10

Switch 10	No. of LCs	Type of control	Type of start	Feedback circuit for external contactors
0	4	2-channel light curtains	auto start	no
1	3	2-channel light curtains	manual start	no
2	3	2-channel light curtains	auto start	yes
3	3	2-channel light curtains	manual start	yes
4-9	position not allowed (failure 5)			

Terminal designation

Terminal	Light curtains / E-stop		Feedback circuit for external contactors
S11	not connected	link S11-S12 without LC1	
S12	LC 1		
S13	not connected	link S13-S14 without LC1	
S14	LC 1		
S21	not connected	link S21-S22 without LC2	
S22	LC 2		
S23	not connected	link S23-S24 without LC2	
S24	LC 2		
S31	E-stop		
S32			
S33			
S34			
S41			Feedback circuit
S42			
S43	start button		
S44			

Semiconductor outputs

Output	Flashing signal	Continuous signal
48	One LC interrupted or e-stop button pressed or failure in feedback circuit or failure in start circuit	
58	Wait for start button	Relay K1, K2 active

Light curtains and E-stop

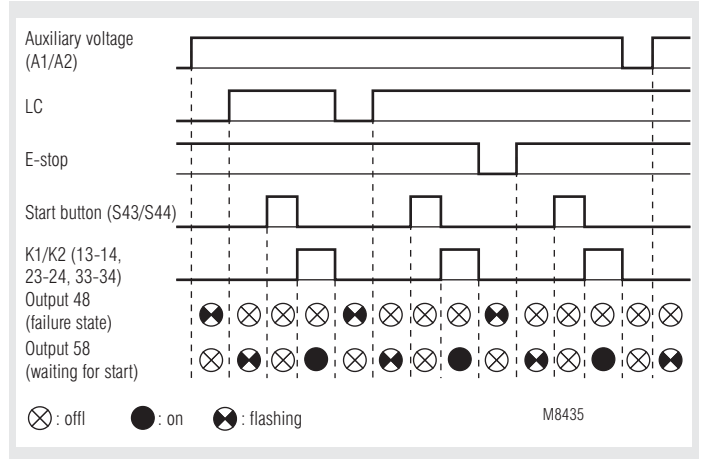
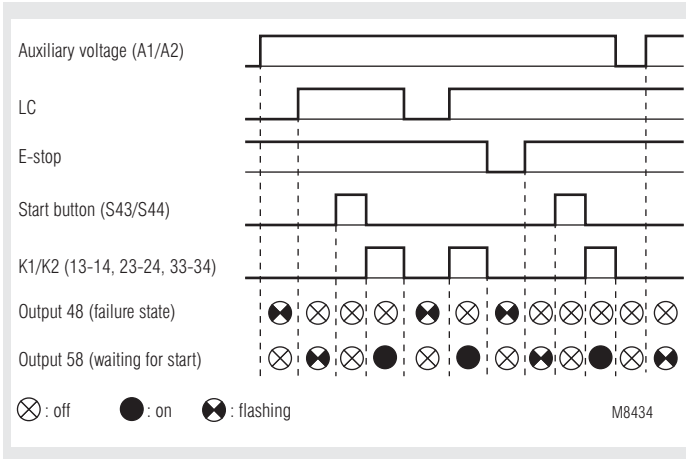

Light curtains and E-stop, auto start

Light curtains and E-stop, manual start

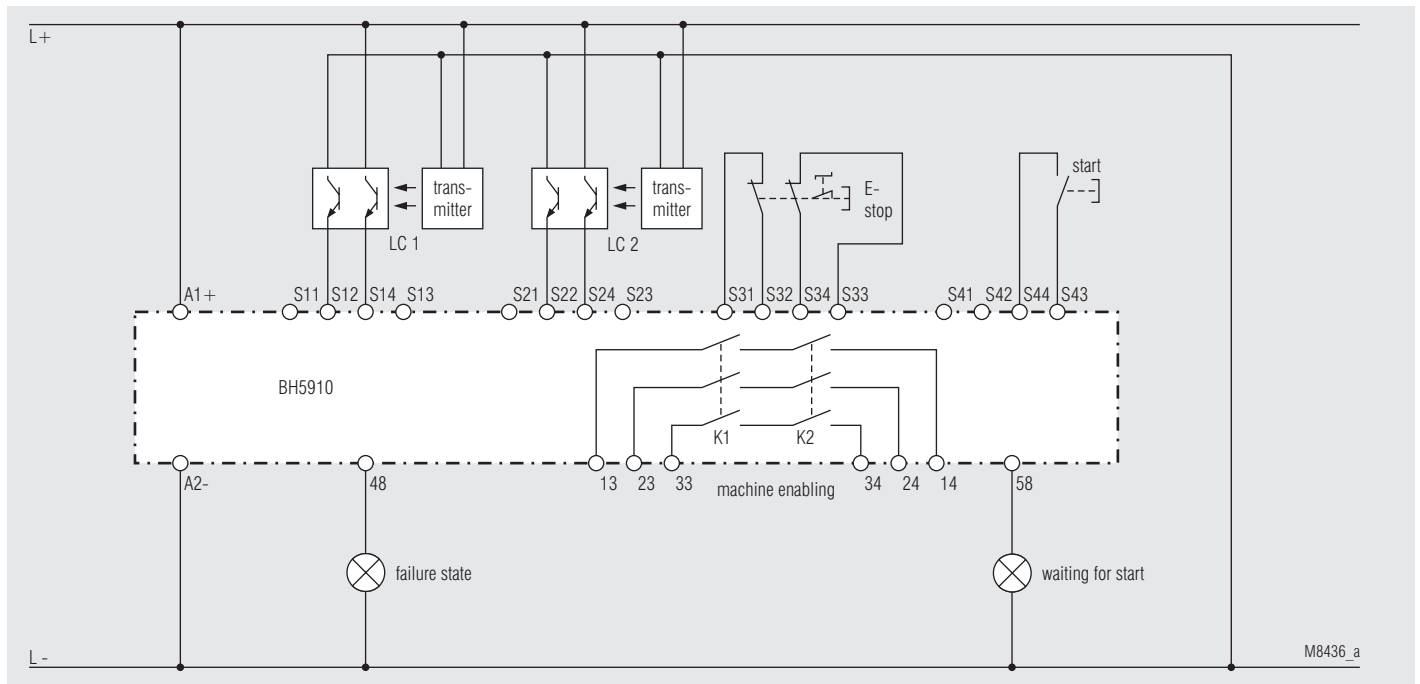

Fig. 7: Light curtains and E-stop, auto start or manual start (switch 1 in position 2, switch 10 in position 0 or 1)

Safety gates (switch 1 in position 3)

With switch 10 the maximum number of gates is selected. Open (unused) inputs (S_1/S_2 and S_3/S_4) have to be linked with a wire bridge. If gate inputs are not used the type of control has to be with simulation button. K1 and K2 can only be activated, if all connected gates have been opened and closed again. Both gate contacts have to be operated within 3 s. If the time difference is longer, the gate has to be opened before it can be closed again. When all gates are closed the unit can also be activated by an external connected Simulation button.

If changeover contacts are used on the gate switches the switchover time has to be less than 50 ms. If it is longer the outputs K1 and K2 are switched off and the unit gives failure code 7. This failure is stored and can only be reset by disconnecting the auxiliary supply.

Function diagram

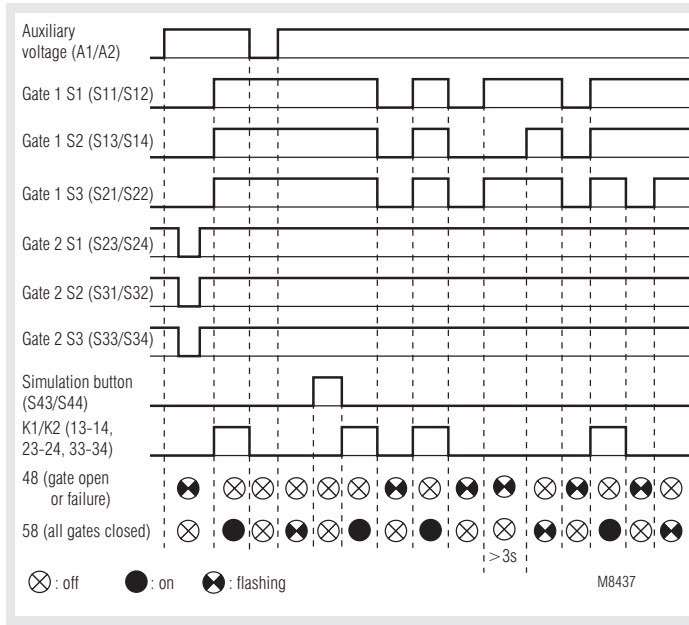

Gate monitor, 2 gates with 3 NO contacts for each gate, Simulation button

Semiconductor outputs

Output	Flashing signal	Continuous signal
48	Open gate or failure in feedback circuit or in start circuit	
58	Gates are closed but starting conditions not fulfilled	Gates are closed and contacts K1, K2 are active

Settings on switch 10

Switch 10	No. of gates	Number and type of gate switches	Simulation button	Feedback circuit for external contactors
0	4	2 NO contacts	no	no
1	3	2 NO contacts	yes	no
2	2	2 C/O contacts	no	no
3	1	2 C/O contacts	yes	no
4	2	3 NO contacts	yes	no
5	1	2 C/O contacts, 1 NO contact	yes	no
6	3	2 NO contacts	yes	yes
7	1	2 C/O contacts	yes	yes
8	2	3 NO contacts	yes	yes
9	1	2 C/O contacts, 1 NO contact	yes	yes

NO contacts must be closed when gate is closed, NC contacts must be open when gate is closed.

Terminal designation

Terminal	max. 2 gates with 3 NO gate contacts	1 gate with 2 C/O + 1 NO gate contacts	max. 4 gates with 2 NO gate contacts	max. 2 gates with 2 C/O gate contacts	Feedback circuit for external contactors simulation
S11 S12	gate 1, S1	gate 1, S1 NO contact gate 1, S1 common connector	gate 1, S1	gate 1, S1 NO contact gate 1, S1 common connector	
S14 S13	gate 1, S2	gate 1, S1 common connector gate 1, S1 NC contact	gate 1, S2	gate 1, S1 common connector gate 1, S1 NC contact	
S21 S22	gate 1, S3	gate 1, S2 NC contact gate 1, S2 common connector	gate 2, S1	gate 1, S2 NC contact gate 1, S2 common connector	
S24 S23	gate 2, S1	gate 1, S2 common connector gate 1, S2 NO contact	gate 2, S2	gate 1, S2 common connector gate 1, S2 NO contact	
S31 S32	gate 2, S2	gate 1, S3	gate 3, S1	gate 2, S1 NO contact gate 2, S1 common connector	
S34 S33	gate 2, S3	not connected	gate 3, S2	gate 2, S1 common connector gate 2, S1 NC contact	
S41 S42	not connected	not connected	gate 4, S1	gate 2, S2 NC contact gate 2, S2 common connector	Feedback circuit
S44 S43			gate 4, S2	gate 2, S2 common connector gate 2, S2 NO contact	Simulation button

Safety gates (switch 1 in position 3); Application examples

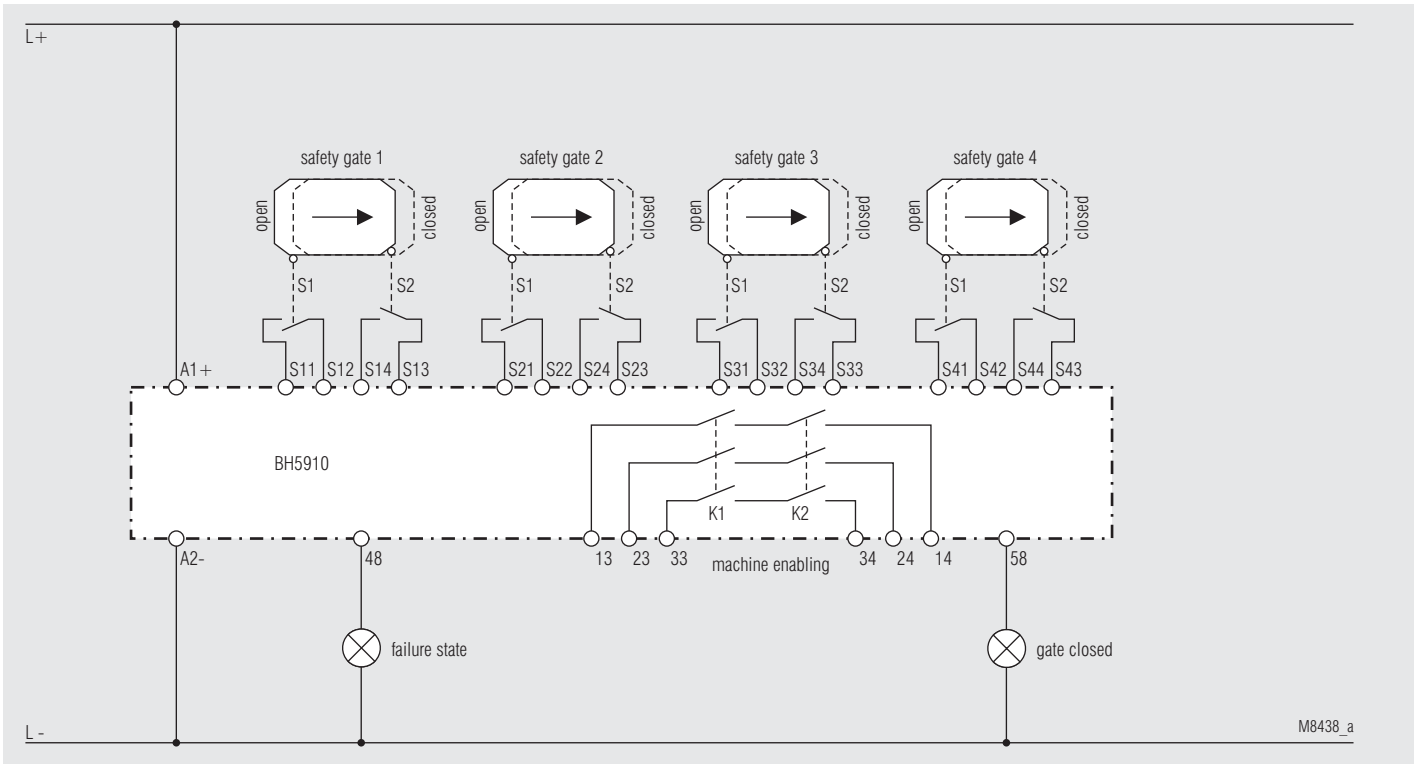

Pic. 8: Gate monitor, 4 gates with 2 NO gate contacts each (switch 1 in position 3; switch 10 in position 0)

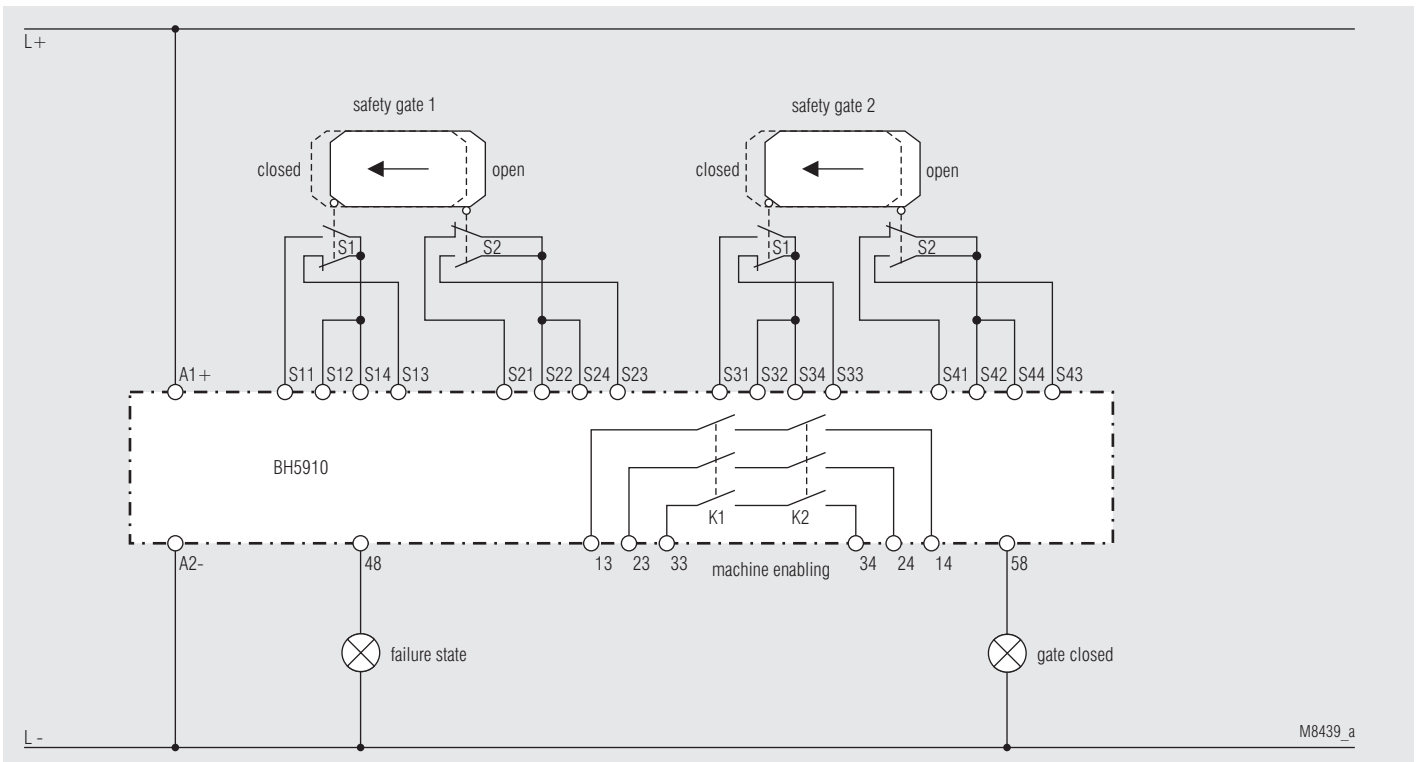

Pic. 9: Gate monitor, 2 gates with 2 changeover gate contacts each (switch 1 in position 3; switch 10 in position 2)

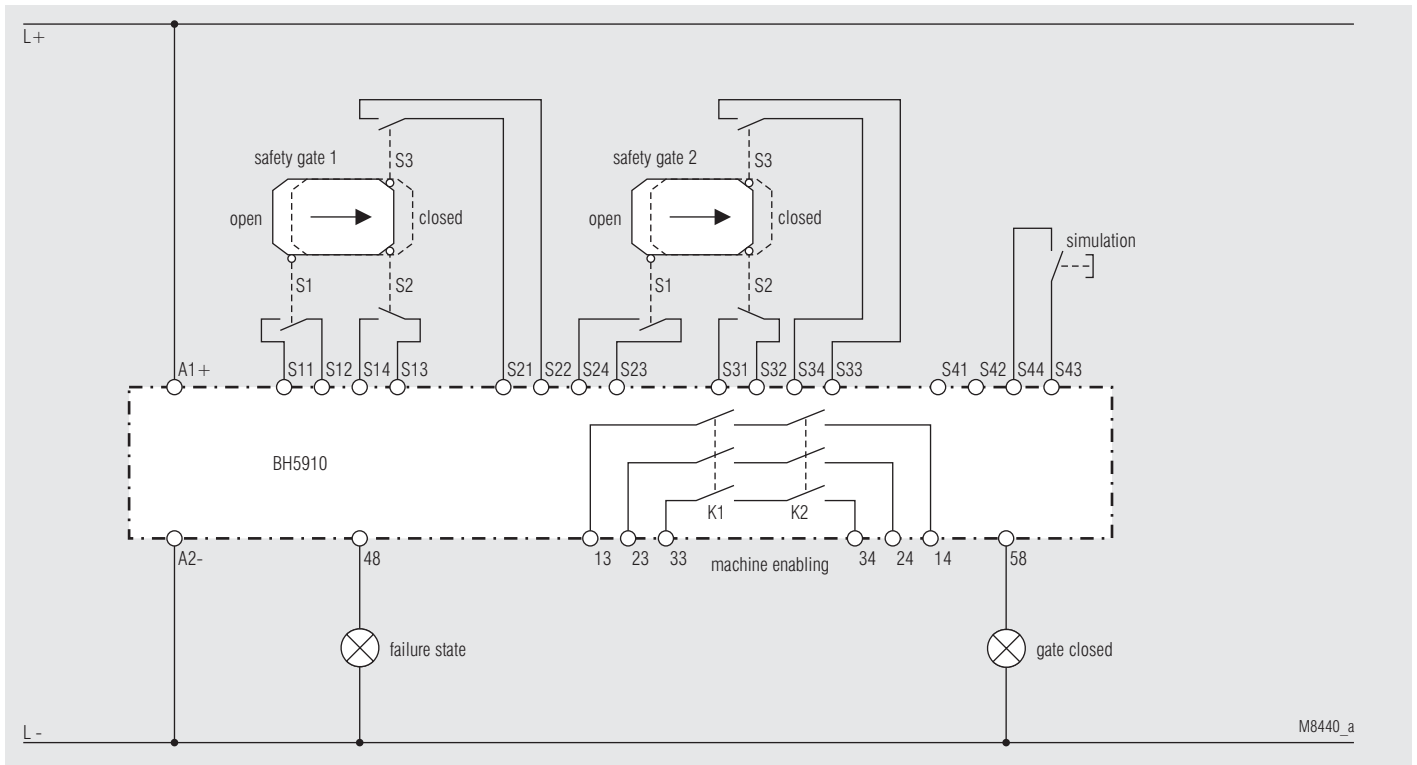

Pic. 10: Gate monitor, 2 gates with 3 NO gate contacts each, simulation button (switch 1 in position 3; switch 10 in position 4)

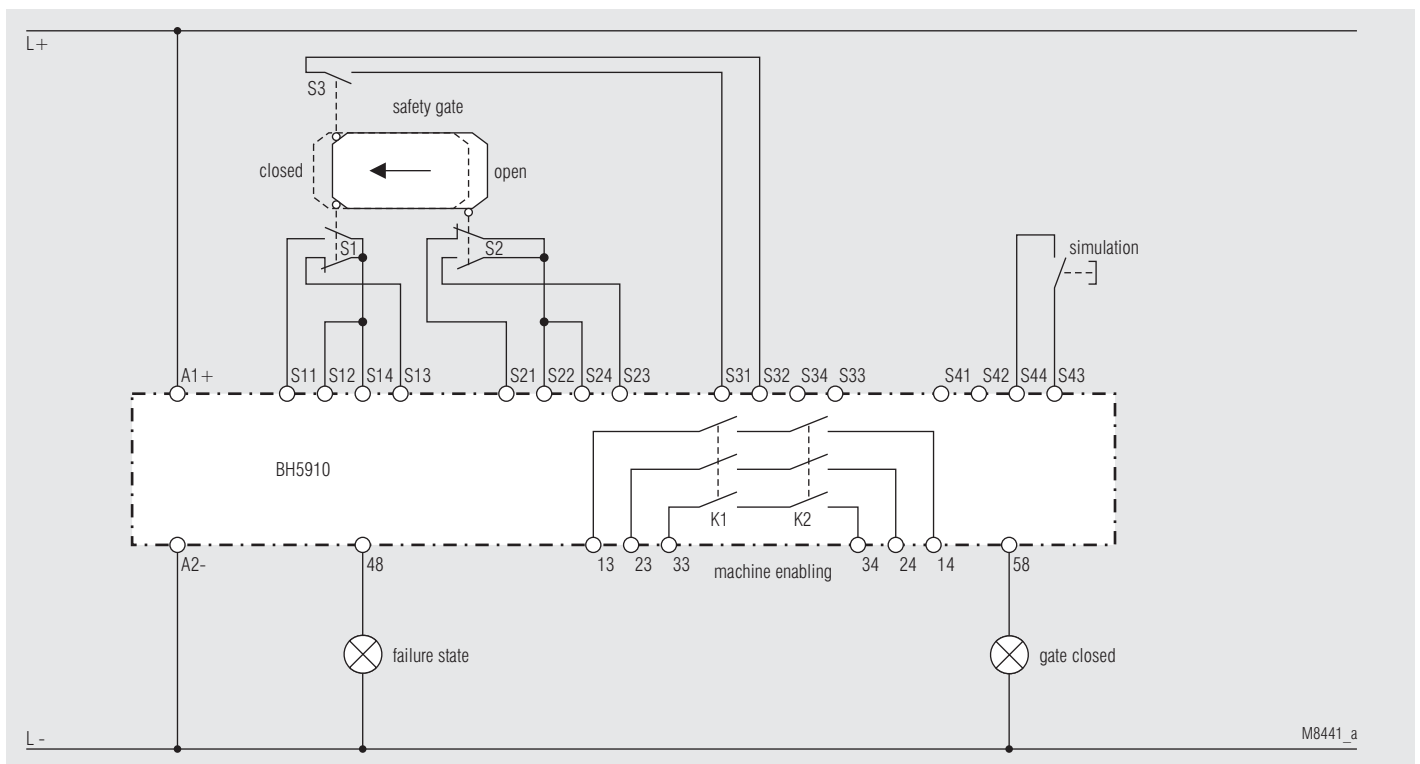

Pic. 11: Gate monitor, 1 gate with 2 changeover gate contacts, simulation button (switch 1 in position 3; switch 10 in position 5)

Safety gates and E-stop (switch 1 in position 4)

With switch 10 the maximum number of gates is selected. Open (unused) inputs (S_1/S_2 and S_3/S_4) have to be linked with a wire bridge.

K1 and K2 can only be activated, if the e-stop loop is closed and all connected gates have been opened and closed again.

Both gate contacts have to be operated within 3 s. If the time difference is longer, the gate has to be opened before it can be closed again. When all gates are closed the unit can also be activated by an external connected simulation button.

After e-stop or power failure the unit can only be reset by manual start.

If changeover contacts are used on the gate switches the switchover time has to be less than 50 ms. If it is longer the outputs K1 and K2 are switched off and the unit gives failure code 7. This failure is stored and can only be reset by disconnecting the auxiliary supply.

Function diagram

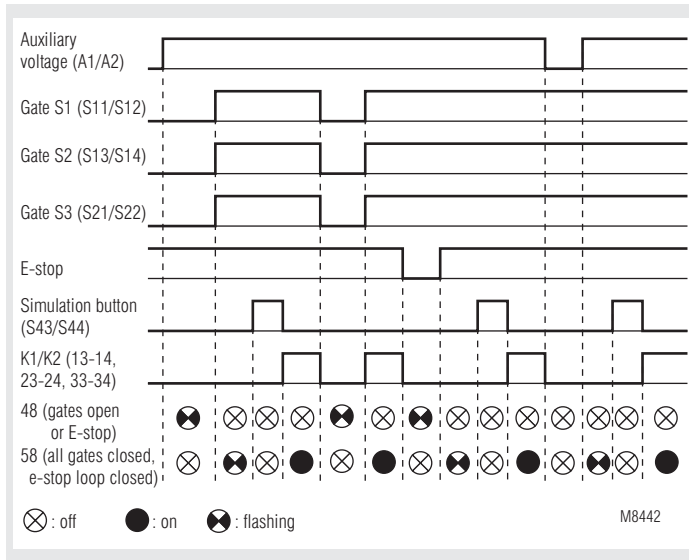

Gate monitor and E-stop,
1 gate with 3 NO gate contacts and e-stop loop

Settings on switch 10

Switch 10	No. of gates	Number and type of gate switches	Simulation button	Feedback circuit for external contactors
0	2	2 NO contacts	yes	no
1	1	2 C/O contacts	yes	no
2	1	3 NO contacts	yes	no
3	2	2 NO contacts	yes	yes
4	1	2 C/O contacts	yes	yes
5	1	3 NO contacts	yes	yes
6-9	position not allowed (failure 5)			

NO contacts must be closed when gate is closed, NC contacts must be open when gate is closed.

Terminal designation

Terminal	1 gate with 3 NO gate contacts	2 gates with 2 NO gate contacts	1 gate with 2 C/O gate contacts	Feedback circuit for external contactors
S11	gate 1, S1	gate 1, S1	gate 1, S1 NO contact	
S12				
S14	gate 1, S2	gate 1, S2	gate 1, S1 common connector gate 1, S1 NC contact	
S13				
S21	gate 1, S3	gate 2, S1	gate 1, S2 NC contact gate 1, S2 common connector	
S22				
S24	not connected	gate 2, S2	gate 1, S2 common connector gate 1, S2 NO contact	
S23				
1 E-stop button, 1 Simulation or start button				
S31	E-stop, channel 1			
S32	E-stop, channel 1			
S34	E-stop, channel 2			
S33	E-stop, channel 2			
S41				feedback circuit
S42				
S44	Simulation or start button			
S43	Simulation or start button			

Semiconductor outputs

Output	Flashing signal	Continuous signal
48	Open gate, e-stop loop open or failure in feedback circuit or failure on simulation button	
58	Gates are closed but starting conditions not fulfilled or e-stop loop has been opened and closed again. K1, K2 can be activated with the simulation button	Gates are closed and contacts K1, K2 are active

Safety gates and E-stop (switch 1 in position 4); Application example

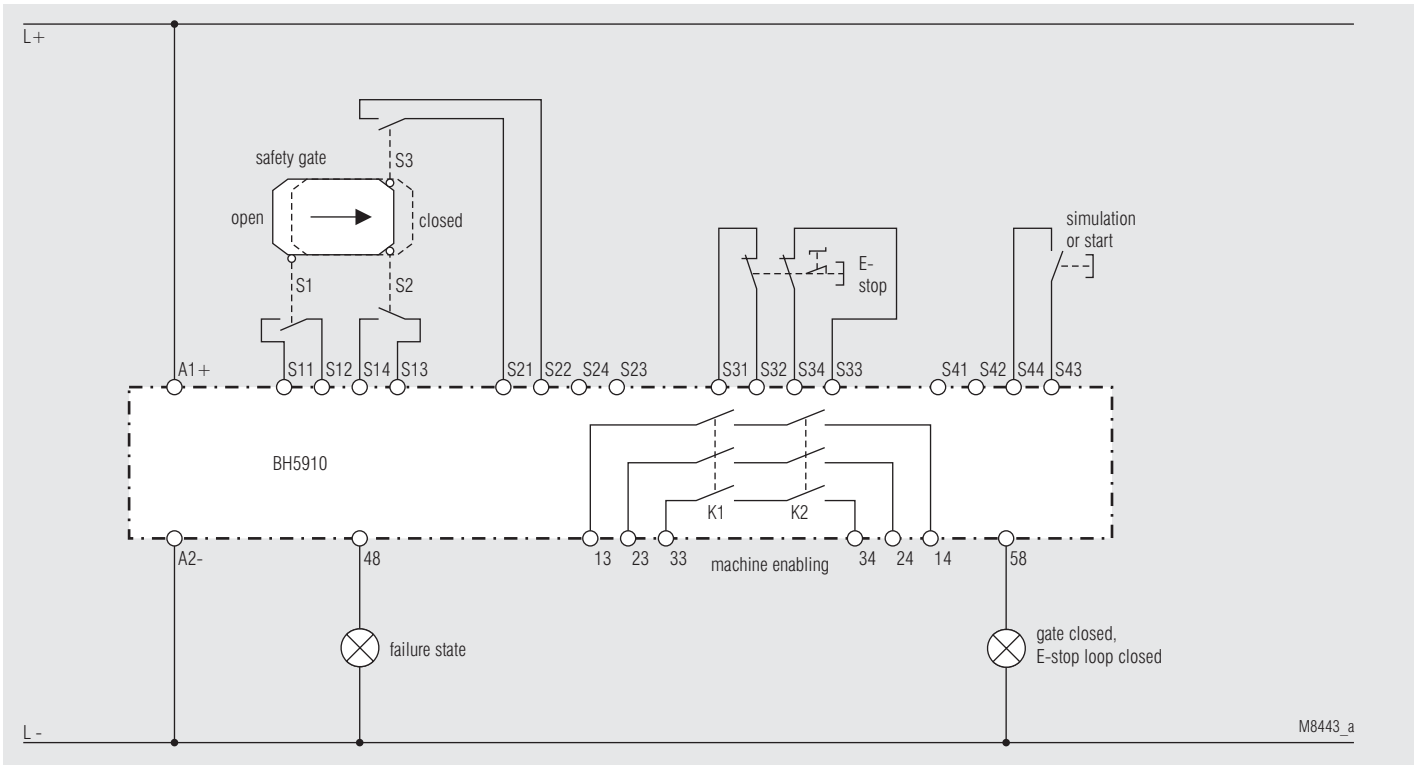

Pic. 12: Gate monitor and E-stop, 1 gate with 3 NO gate contacts and 1 e-stop loop (switch 1 position 4; switch 10 position 2)

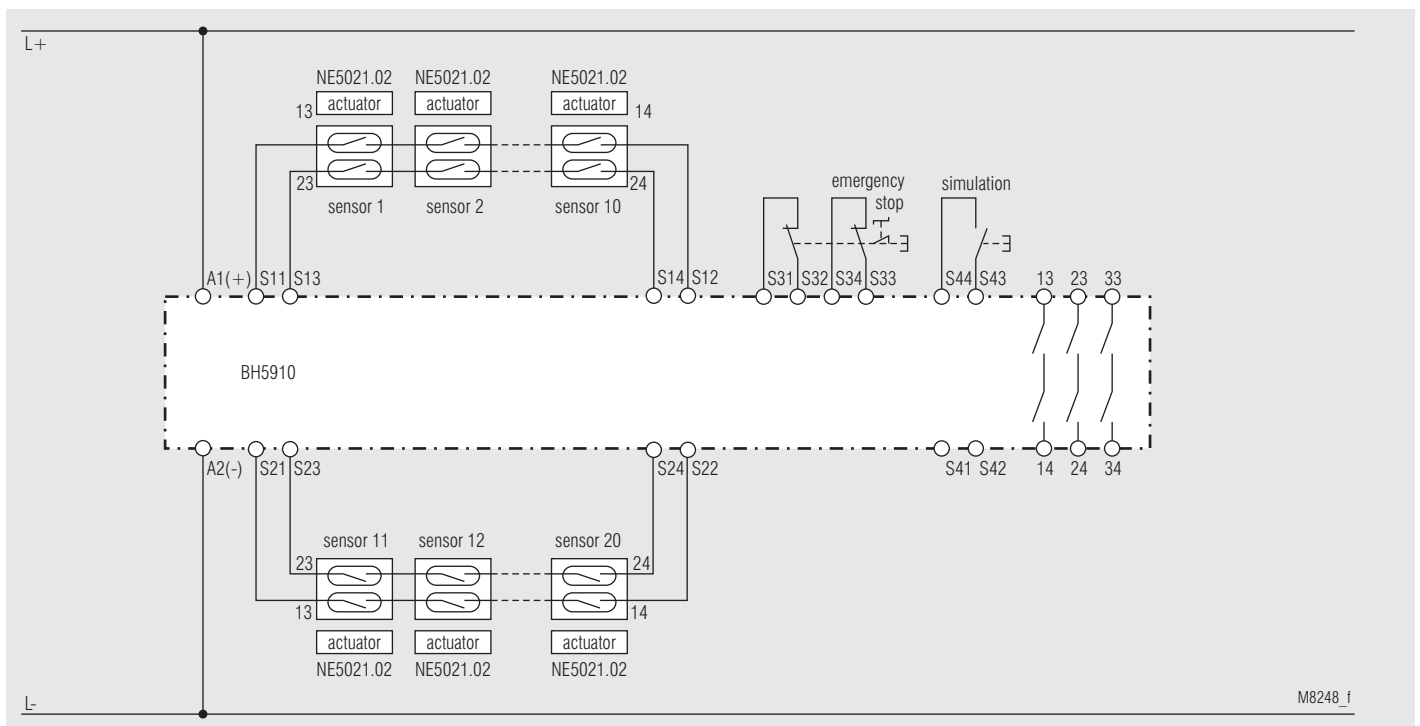

Pic. 13: Gate monitor and E-stop, safety gate monitoring with up to 20 magnetic coded safety switches NE 5021 + 1 e-stop loop (switch 1 position 4; switch 10 position 0 or 3)

2-Hand control (switch 1 in position 5)

4 pairs of 2-hand buttons Typ III A or 2 pairs of 2-hand buttons Typ III C according to DIN EN 574 can be connected in this function. The number of connected button pairs has to be selected on the device. K1 and K2 can only be activated, if 3 conditions are fulfilled:

- First all button pairs have to be in initial position.
- Both buttons of 1 pair have to be pressed within 0.5 sec.
- All connected pairs have to be operated within 15 s.

If changeover contacts are used in the 2-hand buttons the switchover time has to be less than 50 ms. If it is longer the outputs K1 and K2 are switched off and the unit gives failure code 7. This failure is stored and can only be reset by disconnecting the auxiliary supply.

Function diagram

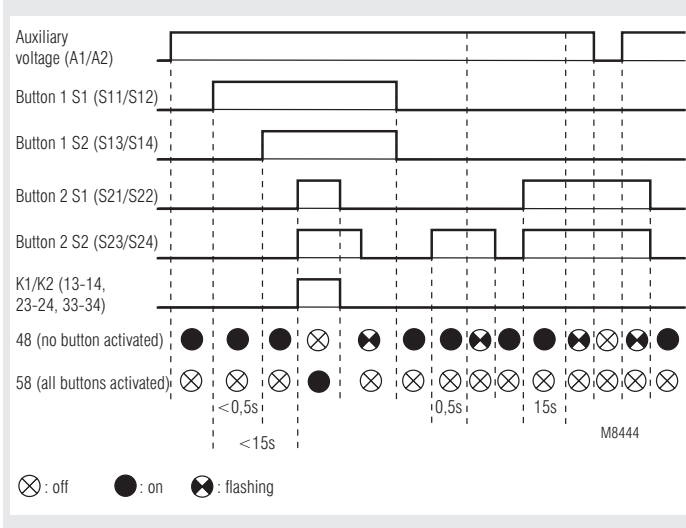

Two-hand control, 2 pairs of buttons with 2 NO contacts each

Set-up instructions

The device has to be connected as shown in the application examples. When connecting the push-buttons in parallel or in series the safe function of the relay is disabled. The buttons must be designed and installed in a way, that it is not possible to manipulate or to operate them without intention.

The distance between push buttons and dangerous area must be chosen in a way that it is not possible to reach the dangerous area after release of one button before the dangerous movement comes to standstill.

The safety distance "S" is calculated with the following formula:
 $S = V \times T + C$

- moving speed of person $V = 1\ 600\ \text{mm/s}$
- stopping time of the machine $T\ (\text{s})$
- Additional safety distance $C = 250\ \text{mm}$

If the risk of accessing the dangerous area is prohibited while the push buttons are pressed e.g. by covering the buttons, C can be 0. The minimum distance has to be in this case 100 mm. See also EN 574.

Settings on switch 10

Switch 10	Number of button pairs	Type fo button contacts	Feedback circuit for external contactors
0	1	2 NO contacts	no
1	2	2 NO contacts	no
2	3	2 NO contacts	no
3	4	2 NO contacts	no
4	1	2 C/O contacts	no
5	2	2 C/O contacts	no
6	1	2 NO contacts	yes
7	2	2 NO contacts	yes
8	3	2 NO contacts	yes
9	1	2 C/O contacts	yes

Terminal designation

Terminal	Pair of buttons with 2 NO contacts each	Pair of buttons with 2 C/O contacts each	Feedback circuit for external contactors
S11 S12	Pair 1, button S1	Pair 1, button S1, NO connector Pair 1, button S1, common connector	
S14 S13	Pair 1, button S2	Pair 1, button S1, common connector Pair 1, button S1, NC connector	
S21 S22	Pair 2, button S1	Pair 1, button S2, NC connector Pair 1, button S2, common connector	
S24 S23	Pair 2, button S2	Pair 1, button S2, common connector Pair 1, button S2, NO connector	
S31 S32	Pair 3, button S1	Pair 2, button S1, NO connector Pair 2, button S1, common connector	
S34 S33	Pair 3, button S2	Pair 2, button S1, common connector Pair 2, button S1, NC connector	
S41 S42	Pair 4, button S1	Pair 2, button S2, NC connector Pair 2, button S2, common connector	Feedback circuit
S44 S43	Pair 4, button S2	Pair 2, button S2, common connector Pair 2, button S2, NO connector	Acknowledge button

Semiconductor outputs

Output	Flashing signal	Continuous signal
48	Starting conditions not fulfilled or failure in feedback circuit or on acknowledge button.	All buttons in initial position. For a new start all buttons have to be activated according to the starting conditions.
58	Press acknowledge button.	All buttons are activated, K1, K2 are energised.

2-hand control (switch 1 in position 5); Application examples

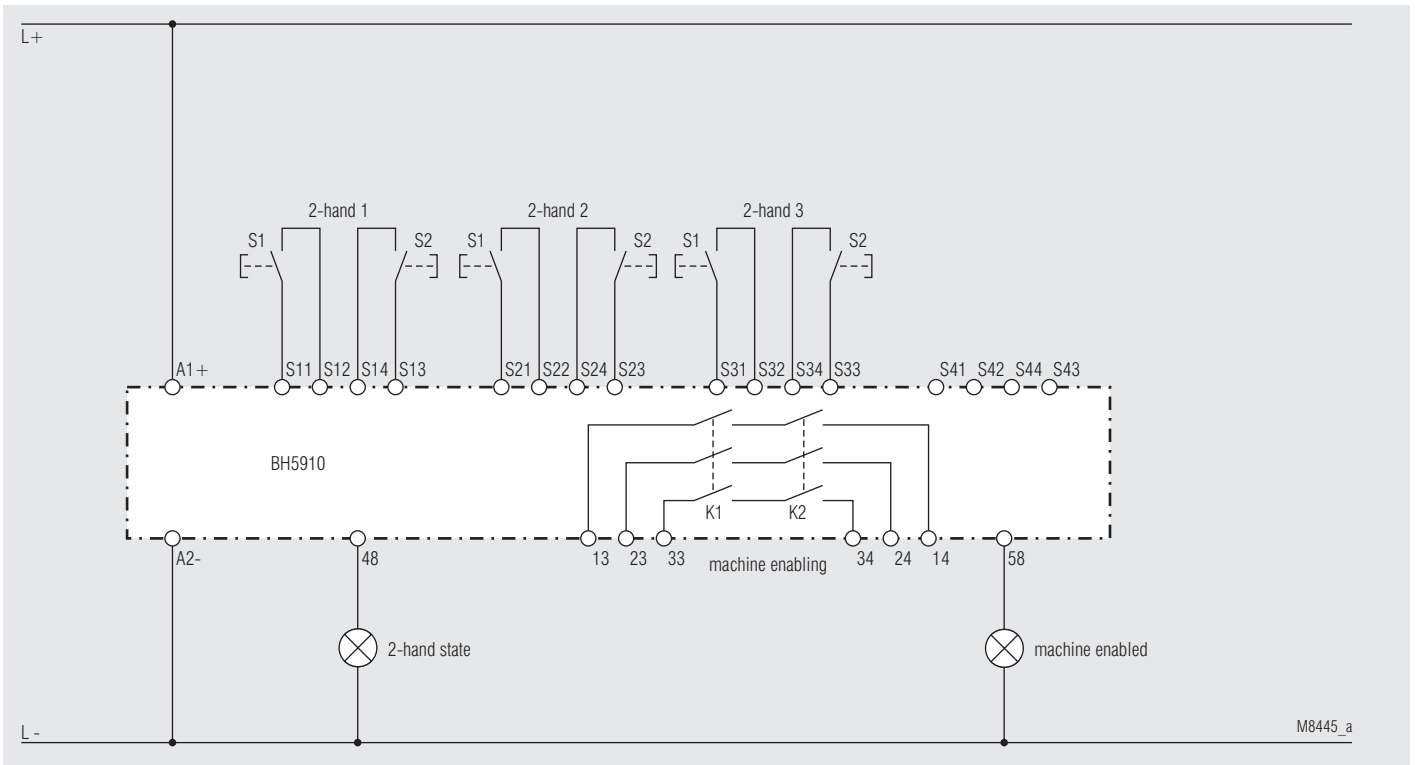

Pic.14: 2-hand control, with 3 pairs of buttons and 2 NO contacts each (switch 1 in position 5; switch 10 in position 2)
Safety switches Typ III A according to DIN EN 574

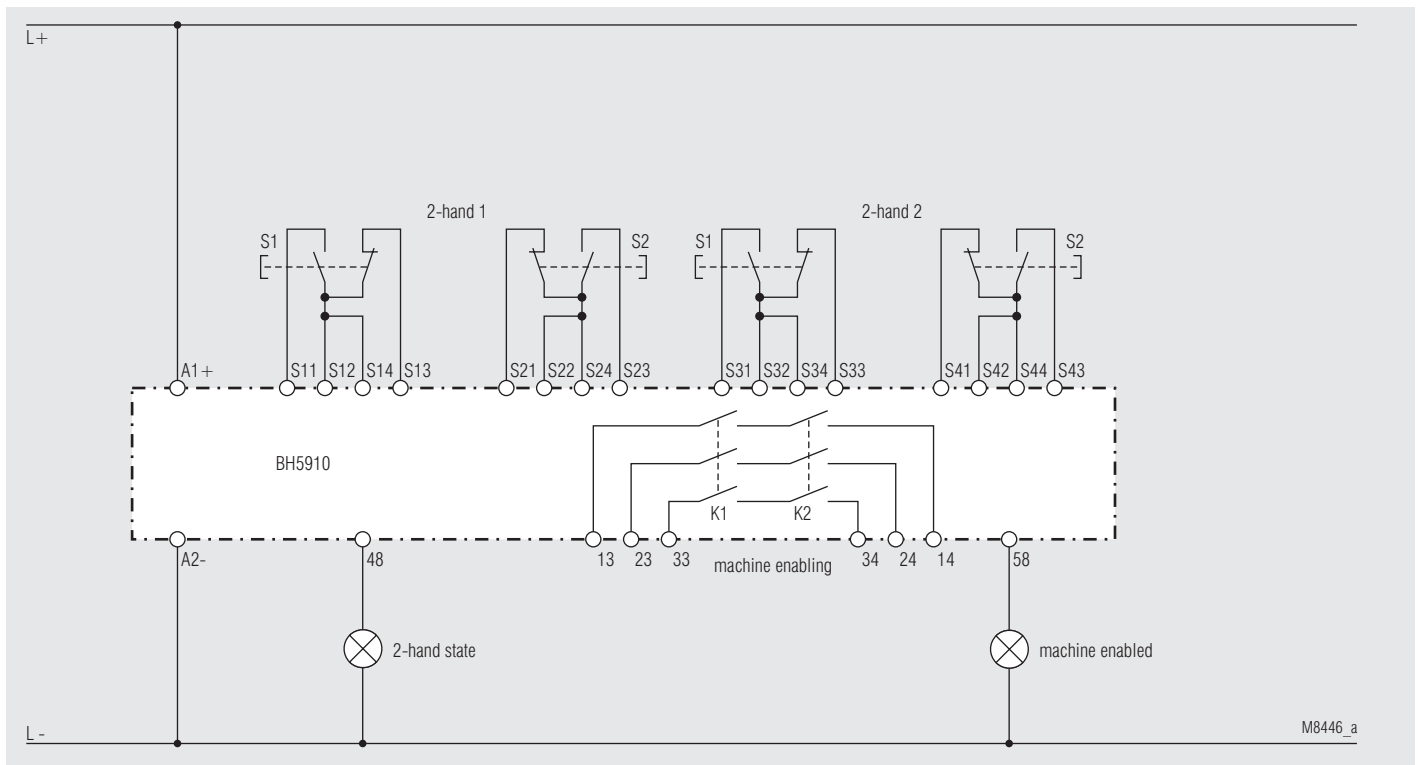

Pic.15: 2-hand control, with 2 pairs of buttons and 2 changeover contacts each (switch 1 in position 5; switch 10 in position 5)
Safety switches Typ III C according to DIN EN 574

2-Hand control and E-stop (switch 1 in position 6)

2 pairs of 2-hand buttons can be connected in this function together with 1 e-stop loop. The number of connected button pairs has to be selected on the device.

K1 and K2 can only be activated, if 4 conditions are fulfilled:

- First all button pairs have to be in initial position.
- The e-stop contacts must be closed and manual start must be activated.
- Both buttons of 1 pair have to be pressed within 0.5 sec.
- All connected pairs have to be operated within 15 sec.

If changeover contacts are used in the 2-hand buttons the switchover time has to be less than 50 ms. If it is longer the outputs K1 and K2 are switched off and the unit gives failure code 7. This failure is stored and can only be reset by disconnecting the auxiliary supply.

After e-stop or power failure the start button must always be activated. The e-stop loop must be closed and all 2-hand button pairs must be in initial position.

Settings on switch 10

Switch 10	No. of button pairs	Type of button pairs	Feedback circuit for external contactors
0	1	2 NO contacts	no
1	2	2 NO contacts	no
2	1	2 C/O contacts	no
3	1	2 NO contacts	yes
4	2	2 NO contacts	yes
5	1	2 C/O contacts	yes
6-9	position not allowed (failure 5)		

Terminal designation

Terminal	Pair of buttons with 2 NO contacts each	Pair of buttons with 2 C/O contacts each	Feedback circuit with external contactor
S11 S12	Pair 1, button S1	button S1, NO connector button S1, common connector	
S14 S13	Pair 1, button S2	button S1, common connector button S1, NC connector	
S21 S22	Pair 2, button S1	button S2, NC connector button S2, common connector	
S24 S23	Pair 2, button S2	button S2, common connector button S2, NO connector	
1 E-stop loop and 1 Start button			
S31 S32	E-stop, channel 1		
S34 S33	E-stop, channel 2		
S41 S42	not connected		Feedback circuit
S44 S43	Start button		

Semiconductor outputs

Output	Flashing signal	Continuous signal
48	E-stop loop open or starting conditions not fulfilled or failure in feedback circuit or on acknowledge button/start button.	All buttons in initial position. For a new start all buttons have to be linked according to the starting conditions.
58	Press acknowledge button.	All buttons are activated, K1, K2 are energised.

Function diagram

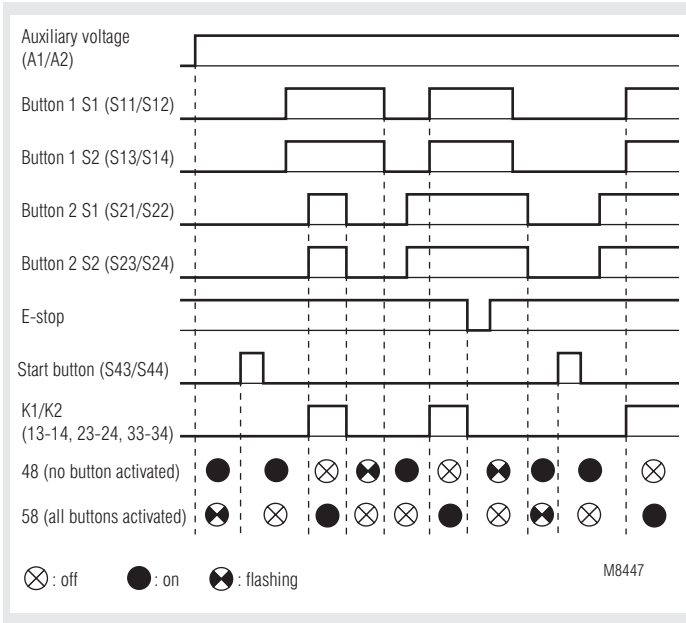

2-hand control and e-stop,
with 2 pairs of buttons with 2 NO contacts each and 1 e-stop loop

Set-up instructions

The device has to be connected as shown in the application examples. When connecting the push-buttons in parallel or in series the safe function of the relay is disabled. The buttons must be designed and installed in a way, that it is not possible to manipulate or to operate them without intention.

The distance between push buttons and dangerous area must be chosen in a way that it is not possible to reach the dangerous area after release of one button before the dangerous movement comes to standstill.

The safety distance "S" is calculated with the following formula:
 $S = V \times T + C$

- moving speed of person $V = 1\,600\text{ mm/s}$
- stopping time of the machine T (s)
- Additional safety distance $C = 250\text{ mm}$

If the risk of accessing the dangerous area is prohibited while the push buttons are pressed e.g. by covering the buttons, C can be 0. The minimum distance has to be in this case 100 mm. See also EN 574.

2-hand control and E-stop (switch 1 in position 6); Application example

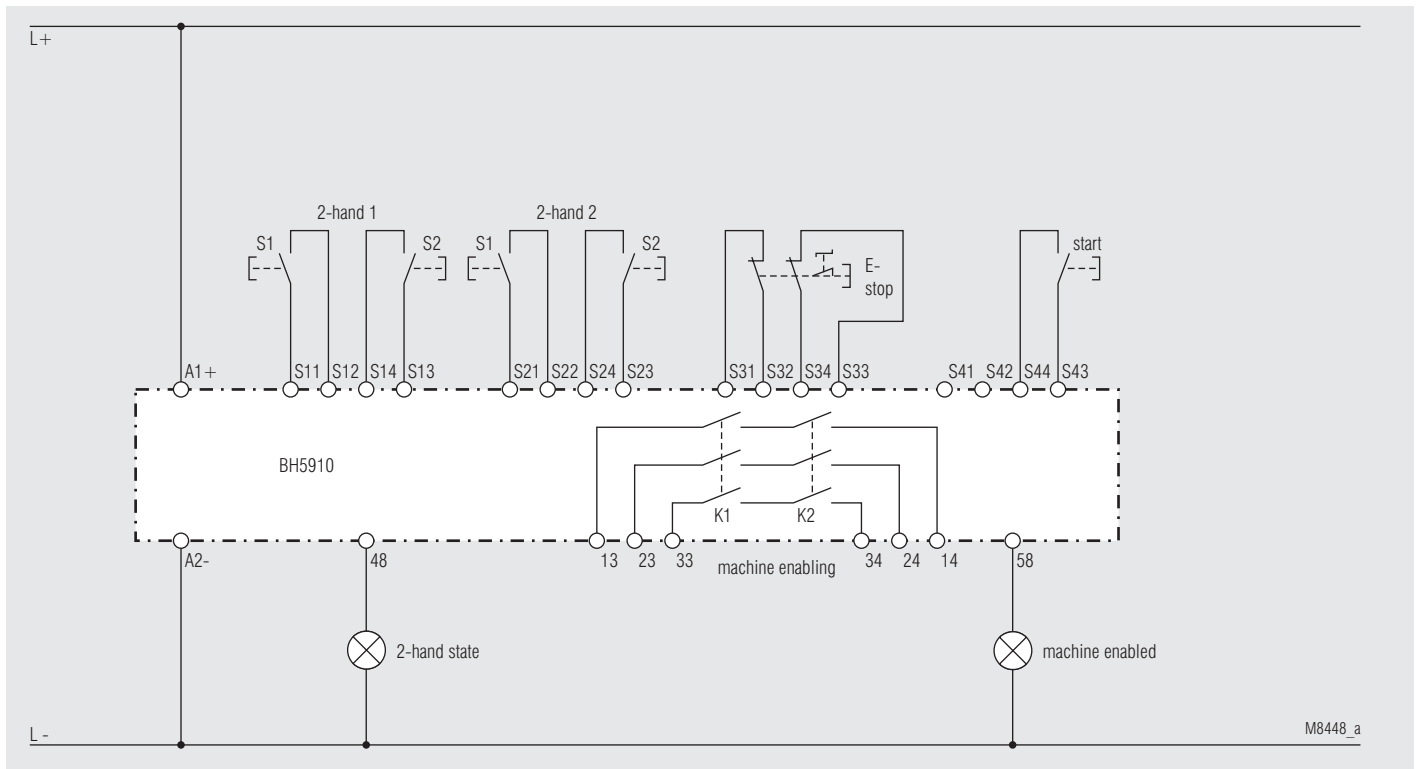

Pic. 16: 2-hand control and e-stop, with 2 pairs of buttons and 2 NO contacts each (switch 1 in position 6; switch 10 in position 1) 2-hand-safety switches Type III A according to DIN EN 574

Circuit diagrams

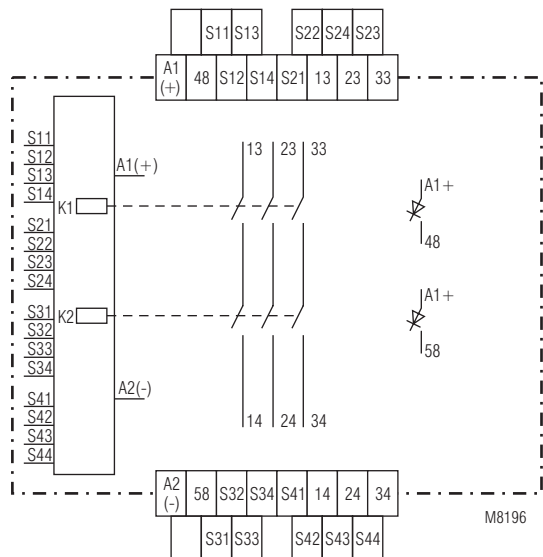

BH 5910.03

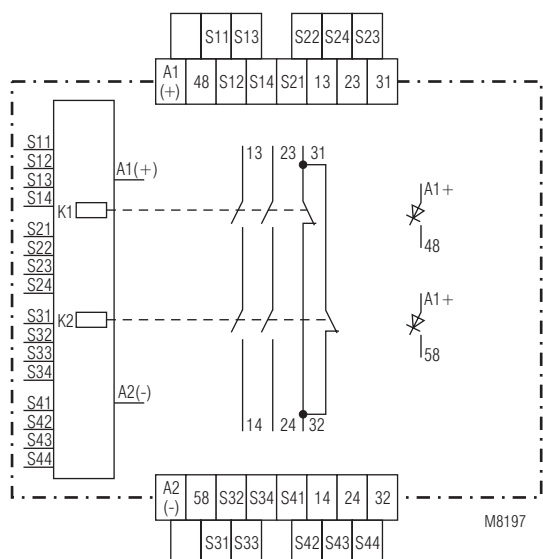

BH 5910.22

Characteristic

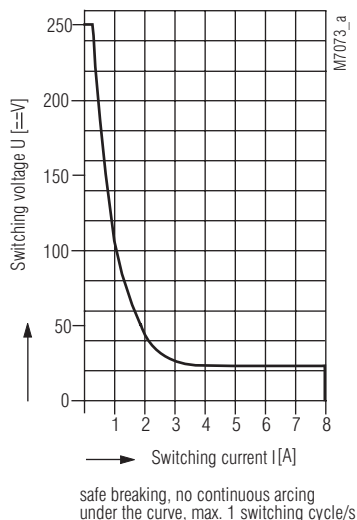

Limit curve for arc-free operation

Technical data

Input

Nominal voltage U_N:	DC 24 V
Voltage range at max. 5 % residual ripple:	0,85 ... 1,15 U_N
Nominal consumption:	max. 170 mA (Semiconductor outputs not connected)
Control voltage on S11, S13, S21, S23, S31, S33, S41, S43, 48, 58:	DC 23 V at U_N
Control current on S12, S14, S22, S24, S32, S34, S42, S44:	4,5 mA at U_N each
Min. voltage at terminals S12, S14, S22, S24, S32, S34 S42, S44:	DC 16 V
Fusing:	internal with PTC

Output

Contacts	BH 5910.03: 3 NO contacts BH 5910.22: 2 NO contacts, 1 NC contact
	The NC contact can only be used as indicator contact.
Contact type:	Relay, positive guided
Einschaltzeit typ. at U_N	

Function	Manual start	auto start	
		Start	Restart
E-stop	45 ms	780 ms	45 ms
Light curtains	45 ms	780 ms	45 ms
Safety gates	45 ms (Simulation)		90 ms (TS)*
2-hand control	54 ms (Activation)		

*) TS = closing of gate

max. switch off time (reaction time)

Function	max. switch off time (reaction time)
E-stop	28 ms
Light curtains	28 ms
Safety gates	28 ms
2-hand control	28 ms

Switching off when failure

in feedback circuit:	max. 100 ms
Nominal output voltage:	AC 250 V DC: see limit curve for arc-free operation
Switching of low loads:	≥ 100 mV
Thermal current I_{th}:	5 A
Switching capacity to AC 15	
NO contact:	3 A / AC 230 V IEC/EN 60 947-5-1
NC contact:	2 A / AC 230 V IEC/EN 60 947-5-1
to DC 13 at 0,1 Hz:	8 A / DC 24 V IEC/EN 60 947-5-1
Electrical life to AC 15 at 2 A, AC 230 V:	10^5 switching cycles IEC/EN 60 947-5-1
Permissible switching frequency:	max. 1 200 switching cycles / h
Short circuit strength	
max. fuse rating:	6 A gL IEC/EN 60 947-5-1
line circuit breaker:	C 8 A
Mechanical life:	10×10^6 switching cycles

Semiconductor outputs

Output (terminal 48 and 58):	transistor outputs, switching +
Nominal output voltage:	DC 24 V, max. 100 mA continuous current, max. 400 mA for 0,5 s internal short circuit, over temperature and overload protection

Technical data

General data

Operating mode:	Continuous operation	
Temperature range:	± 0 ... + 50 °C	
Clearance and creepage distances		
rated impuls voltage / pollution degree:	4 kV / 2	IEC 60 664-1
EMC		
Electrostatic discharge:	8 kV (contact) (according to test degree 3)	IEC/EN 61 000-4-2
HF-irradiation:	10 V / m	IEC/EN 61 000-4-3
Fast transients on wires for power supply A1-A2:	2 kV	IEC/EN 61 000-4-4
on signal and control wires:	2 kV	IEC/EN 61 000-4-4
Surge voltages between		
wires for power supply:	1 kV	IEC/EN 61 000-4-5
between wire and ground:	2 kV	IEC/EN 61 000-4-5
HF-wire guided:	10 V	
Interference suppression:	Limit value class B	EN 55 011
Degree of protection:	according to IEC/EN 61 496-1 (1997) the unit has to be mounted in a control cabinet with protection class 54	
Housing:	IP 40	IEC/EN 60 529
Terminals:	IP 20	IEC/EN 60 529
Housing:	Thermoplastic with V0 behaviour according to UL subject 94	
Vibration resistance:	according to IEC/EN 61 496-1 (1997) Amplitude 0,35 mm IEC/EN 60 068-2-6 frequency 10 ... 55 Hz	
Shock proof:		
Acceleration:	10 g	
Impulse length:	16 ms	
Number of shocks:	1000 per axis on all 3 axes	
Climate resistance:	0 / 050 / 04	IEC/EN 60 068-1
Terminal designation:	EN 50 005	
Wire connection:	1 x 2,5 mm ² stranded wire with sleeve or 1 x 4 mm ² solid or 2 x 1,5 mm ² stranded wire with sleeve DIN 46 228-1/-2/-3/-4	
Wire fixing:	Plus-minus terminal screws M3,5 box terminals with wire protection	
Mounting:	DIN rail	IEC/EN 60 715
Weight:	320 g	

Dimensions

Width x height x depth: 45 x 84 x 121 mm

Standard type

BH 5910.03/00MF2 DC 24 V

Article number:	0054217
• Output:	3 NO contacts
• All functions selectable via rotational switches	
• Nominal voltage U _N :	DC 24 V
• Width:	45 mm

Ordering example

BH 5910 . _ _ /00MF2 DC 24 V

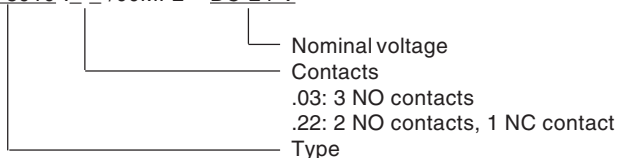

Variants

BH 5910/61: with UL-approval

Fault indication by flashing code

The failure codes are displayed by a flashing sequence of the upper yellow LEDs run 1, run 2. Flashing frequency: env. 0,5 s on, 0,05 s off, end of the sequence: env. 2 s off. It is possible that the two processors show different failure codes.

If a failure is displayed, the relays K1 and K2 are switched off.

These failures are serious and do not allow further operation of the module. They are indicated only by the LEDs run 1 and / or run 2 of the module. The semiconductor outputs 48 and 58 are both switched off. The module can only be reset by switching the power supply off and on again.

No. *)	Description	Measures and hints
0	Internal failure (LEDs constantly off).	If both LEDs are off the relay is defective and has to be sent back for examination.
5	Wrong setting	1) The settings of 2 channels are different, adjust both channels to the same code. 2) The selected setting is not valid.
6	Undervoltage detection Overvoltage detection	1) The left LED flashes, the supply voltage is dropped under approx. 0.85 of the nominal voltage. 2) The right LED flashes, the supply voltage rose too high over approx. 1.15 of the nominal voltage.
7	Input failure	1) A short circuit occurred on the inputs. 2) The 2 signals of a 2-channel sensor (E-stop button, light curtain) are not identical. (Short circuit, broken wire, other defects).
8	Failure on output relays K1, K2	1) Check circuit and switching current. Module has to be sent back for repair.
9	Internal failure	Please try to evaluate the circumstances that led to this fault and check with the supplier or manufacturer.
10		
11		
12	Internal failure	The relay has to be sent back for repair.
13		

*) No.: Number of flash pulses in a series

