

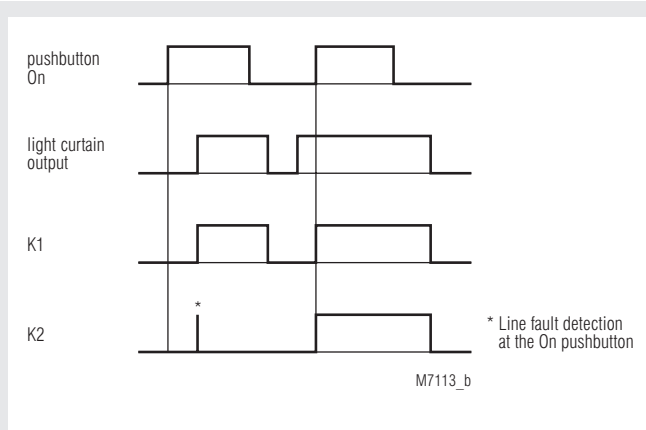

Function diagram

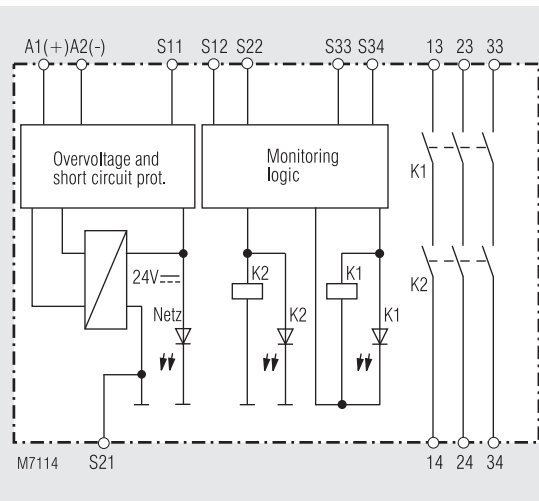

Block diagram



Circuit diagrams

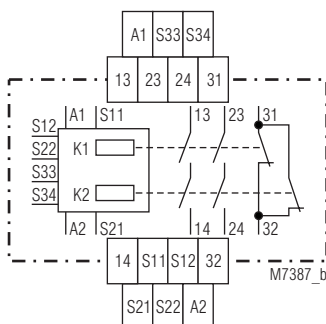

BG 5925.22/900

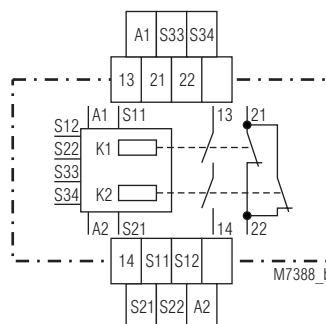

BG 5925.16/900

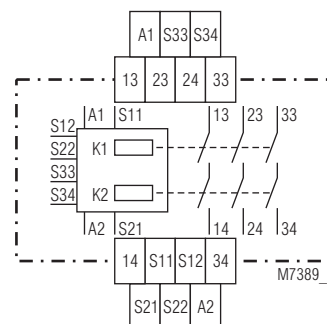

BG 5925.03/900

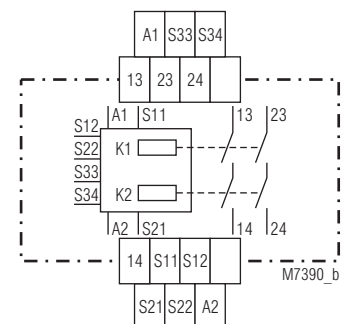

BG 5925.02/900

- According to
 - SIL-Claimed Level (SIL CL) 3 to EN 62061
 - Performance Level (PL) e to DIN EN ISO 13849-1
 - Category 4 to EN 954-1
- Output: max. 3 NO contacts, see contacts
- Single and 2-channel operation
- Line fault detection on On-button
- Manual restart or automatic restart when connecting the supply voltage, switch S2
- For light curtains with symmetric or asymmetric outputs, selection via S1
- Option: fast auto start
- LED indicator for state of operation
- LED indicator for channel 1 and 2
- Removable terminal strips
- Wire connection: also 2 x 1.5 mm² stranded ferruled (isolated), DIN 46 228-1/-2/-3/-4 or 2 x 2.5 mm² stranded ferruled DIN 46 228-1/-2/-3
- Width 22.5 mm

Approvals and marking



Applications

Protection of people and machines

– switch gear (FSD) for light bars with selftest (type 4) according to IEC/EN 61 496-1

Indicators

upper LED: on when supply connected
lower LEDs: on when relay K1 and K2 energized

Notes

The category of a safety relevant part of a control circuit according to EN 954-1 can be different to the category 4 of the E-stop module BG 5925 depending on the external connections.

Line fault detection on On-button:

The line fault detection is only active when S12 and S22 are switched simultaneously. If the On-button is closed before S12, S22 is connected to voltage (also when line fault across On-Button), the output contacts will not close.

A line fault across the On-button which occurred after activation of the relay, will be detected with the next activation and the output contacts will not close. If a line fault occurs after the voltage has been connected to S12, S22, the unit will be activated because this line fault is similar to the normal On-function.

The gold plated contacts of the BG 5925 mean that this module is also suitable for switching small loads of 1 mVA - 7 VA, 1 mW - 7 W in the range 0.1 - 60 V, 1 - 300 mA. The contacts also permit the maximum switching current. However since the gold plating will be burnt off at this current level, the device is no longer suitable for switching small loads after this.

To operate light curtains with symmetric outputs switch S1 has to be in upper position "nicht querschlußsicher".

To operate light curtains with asymmetric outputs (1 output switches Plus,

Unit programming

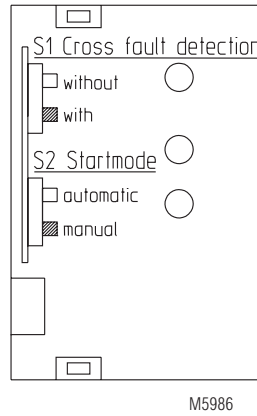
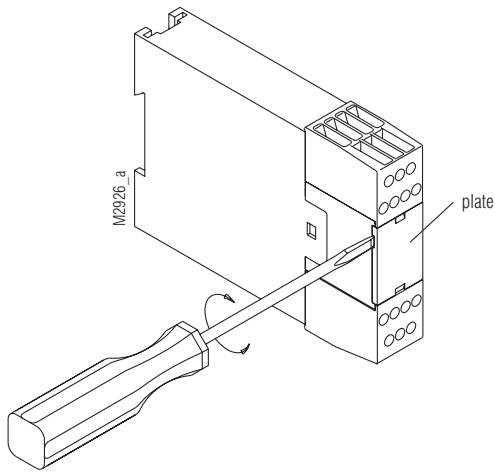

no cross fault detection:
Light bars with symmetric outputs

cross fault detection:
Light bars with asymmetric outputs

Drawing shows setting at the state of delivery

Notes

1 output switches Minus) the switch S1 has to be put in lower position "querschlusicher".
The minus switching channel has to be connected to S22, the plus switching channel to S12.

Technical Data

Input circuit

Nominal Voltage U_N:	DC 24 V
Voltage range	DC
at 10% residual ripple:	0.9 ... 1.1 U_N
Nominal consumption:	DC approx. 2 W
Min. Off-time:	250 ms
Control voltage on S11:	DC 23 V at U_N
Control current over S12, S22:	40 mA at U_N
Min. voltage between terminals S12, S22 and S21:	DC 21 V when relay activated and U_N on A1 - A2
Short-circuit protection:	Internal PTC
Overvoltage protection:	Internal VDR

Output

Contacts	
BG 5925.02:	2 NO contacts
BG 5925.03:	3 NO contact
BG 5925.16:	1 NO, 1 NC contact
BG 5925.22:	2 NO, 1 NC contact
	The NO contacts are safety contacts.
	ATTENTION! The NC contacts 21-22
	or 31-32 can only be used for monitoring.
Operate delay typ. at U_N:	
Manual start:	40 ms
automatic start:	250 ms
BG 5925.__/901:	100 ms
Release delay typ. at U_N:	
Disconnecting the supply:	50 ms
Disconnecting S12, S22:	15 ms
In the case that S22 is not disconnected because of fault:	≤ 200 ms
Contact type:	positive guided
Nominal output voltage:	AC 250 V
	DC: see limit curve for arc-free operation
Switching of low loads:	≥ 100 mV
(contact 5 μ Au)	≥ 1 mA
Thermal current I_{th}:	see current limit curve
on 1 contact path:	max. 8 A
on more than 1 contact path:	max. 7 A per contact path

Technical data

Switching capacity

to AC 15:		IEC/EN 60 947-5-1
NO contact:	AC 3 A / 230 V	
NC contact:	AC 2 A / 230 V	IEC/EN 60 947-5-1
to DC 13:		IEC/EN 60 947-5-1
NO contact:	2 A / 24 V	
NC contact:		
2 contacts in series:	8 A / 24 V > 10 ⁵	
	ON: 0.4 s, OFF: 9.6 s	

Electrical contact life

to AC 15 at 2 A, AC 230 V:	10 ⁵ switching cycles IEC/EN 60 947-5-1
to DC 13 at 2 A, DC 24 V:	> 150 x 10 ³ switching cycles

Permissible operating frequency:

max. 1 200 operating cycles / h

Short circuit strength

max. fuse rating:
line circuit breaker:

6 A general-purpose IEC/EN 60 947-5-1

Mechanical life:

10 x 10⁶ switching cycles

General Data

Operating mode:

Continuous operation

Temperature range:

- 15 ... + 55 °C

Clearance and creepage distances

rated impuls voltage / pollution degree:	4 kV / 2	IEC 60 664-1
--	----------	--------------

EMC

Electrostatic discharge:	8 kV (air)	IEC/EN 61 000-4-2
HF irradiation:	10 V / m	IEC/EN 61 000-4-3
Fast transients:	2 kV	IEC/EN 61 000-4-4

Surge voltages between

wires for power supply:	1 kV	IEC/EN 61 000-4-5
between wire and ground:	2 kV	IEC/EN 61 000-4-5

Interference suppression:

Limit value class B EN 55 011

Degree of protection

Housing:	IP 40	IEC/EN 60 529
Terminals:	IP 20	IEC/EN 60 529

Housing:

Thermoplastic with V0 behaviour according to UL subject 94

Vibration resistance:

Amplitude 0.35 mm IEC/EN 60 068-2-6 frequency 10 ... 55 Hz

Climate resistance:

15 / 055 / 04 IEC/EN 60 068-1

Terminal designation:

EN 50 005

Wire connection:

1 x 4 mm² solid or
1 x 2.5 mm² stranded ferruled (isolated) or
2 x 1.5 mm² stranded ferruled (isolated)
DIN 46 228-1/-2/-3/-4 or
2 x 2.5 mm² stranded ferruled
DIN 46 228-1/-2/-3

Wire fixing:

Box terminal with wire protection, removable terminal strips

Mounting:

DIN rail IEC/EN 60 715

Weight:

220 g

Dimensions

Width x height x depth:	22.5 x 84 x 121 mm
--------------------------------	--------------------

Safety related data

Probability of dangerous Failure per Hour (PFH_b): $9.91 \cdot 10^{-10}$ 1/h

Safe Failure Fraction (SFF): 99.0 %

Proof Test Intervall (T1): 20 Years



The values stated above are valid for the standard type. Safety data for other variants are available on request

Standard type

BG 5925.02/900 DC 24 V
 Article number: 0050918
 • Output: 2 NO contacts
 • Nominal voltage U_N: DC 24 V
 • Width: 22.5 mm

Variant

BG 5925._._/901: unit with fast autostart, switch 2 on "Autostart". Without line fault detection on ON-button when S2 on "Handstart"

Ordering example for Variant

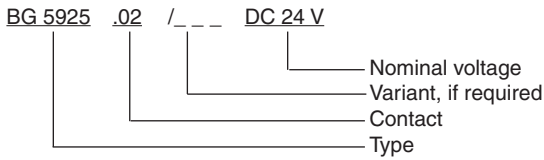

Characteristics

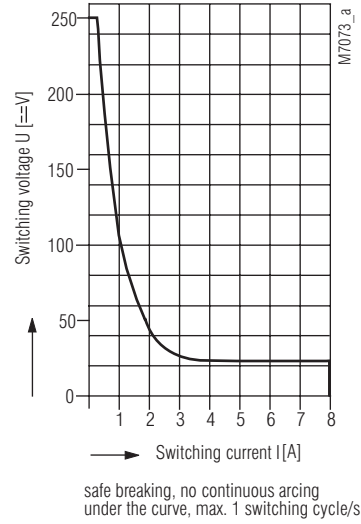

Arc limit curve under resistive load

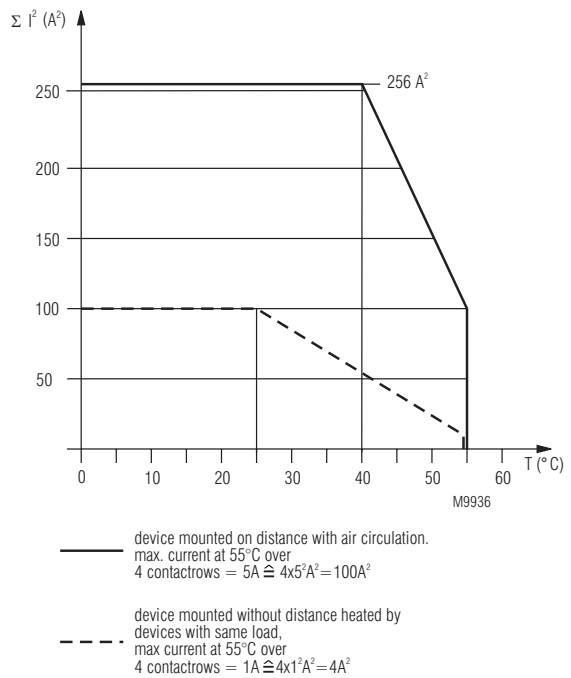

$$\Sigma I^2 = I_1^2 + I_2^2 + I_3^2 + I_4^2$$

I₁, I₂, I₃, I₄ - current in contactrows

Quadratic total current limit curve

electric life DC13 24V DC / t_{on} 0,4s; t_{off} 9,6s
 2 contacts in series

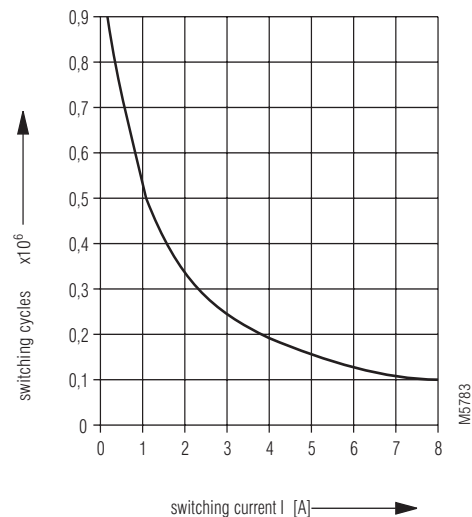

Contact service life

Application example

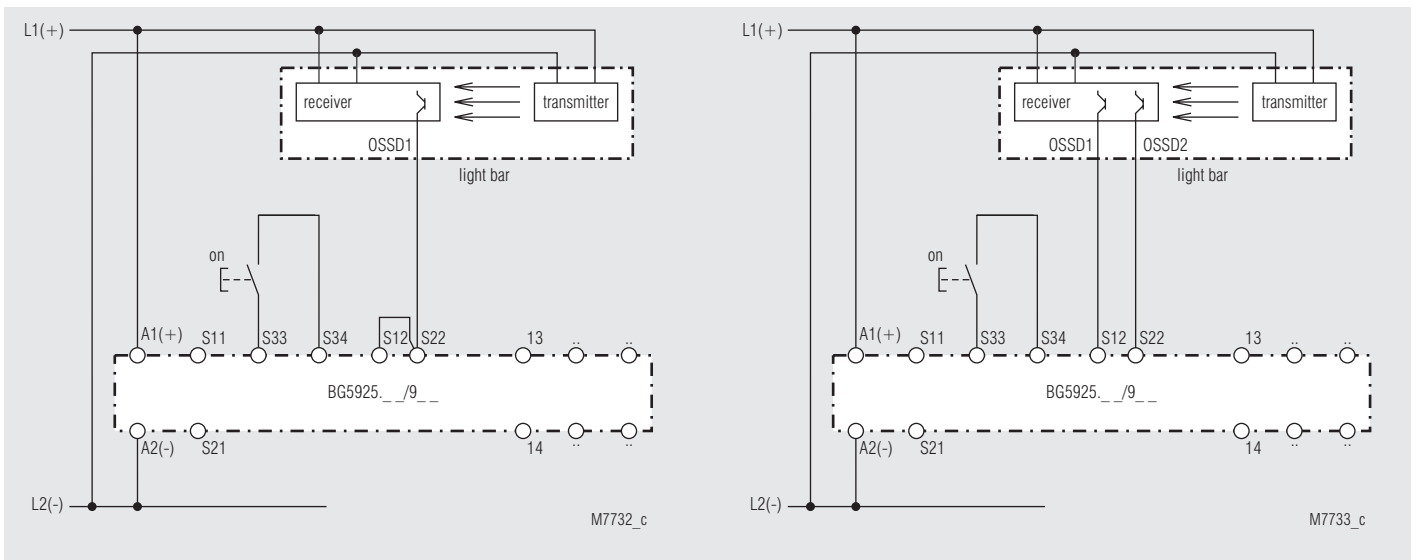

1-channel control by light bar with selftest according to EN 61 496-1

Note: Refer to "Unit programming"!

Switches in pos.: S1: "no cross fault detection"
S2: manual start

2-channel control by light bar with selftest according to EN 61 496-1.

Crossfault monitoring by light bar.

Note: Refer to "Unit programming"!

Switches in pos.:
S1: On light curtains with symmetric outputs S1 in upper position (no cross fault detection).

On light curtains with asymmetric outputs S1 in lower position (cross fault detection).

S2: manual start

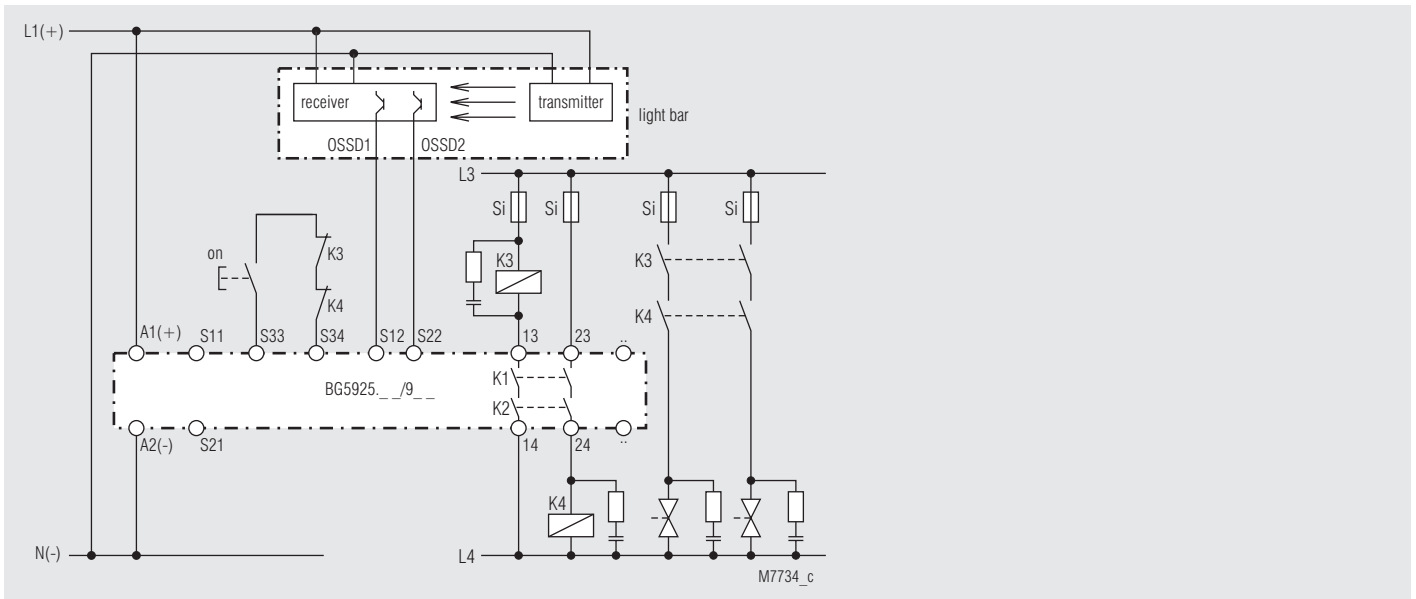

Reinforcement and multiplication of contacts by external contactors

Note: Refer to "Unit programming"!

Switches in pos.:

S1: On line curtains with symmetric outputs S1 in upper position (no cross fault detection).

On line curtains with asymmetric outputs S1 in lower position (cross fault detection).

S2: manual start