

Now with selectable
Plug-in technology



0243372

- According to
 - SIL Claimed Level (SIL CL) 3 to EN 62061
 - Performance Level (PL) e to DIN EN ISO 13849-1
 - Category 4 to EN 954-1
- Output: max. 8 NO contacts, see contacts
- Single and 2-channel operation
- Line fault detection on On-button
- Manual restart or automatic restart when connecting the supply voltage, switch S2
- With or without cross fault monitoring in the E-stop loop, switch S1
- LED indicator for state of operation
- LED indicator for channel 1 and 2
- Removable terminal strips
- Wire connection: also 2 x 1.5 mm² stranded ferruled, or 2 x 2.5 mm² solid DIN 46 228-1/-2/-3/-4
- As option with pluggable terminal blocks for easy exchange of devices
 - with screw terminals
 - or with cage clamp terminals
- LG 5925: 22.5 mm width
- LH 5925: 45 mm width

Options with pluggable terminal blocks

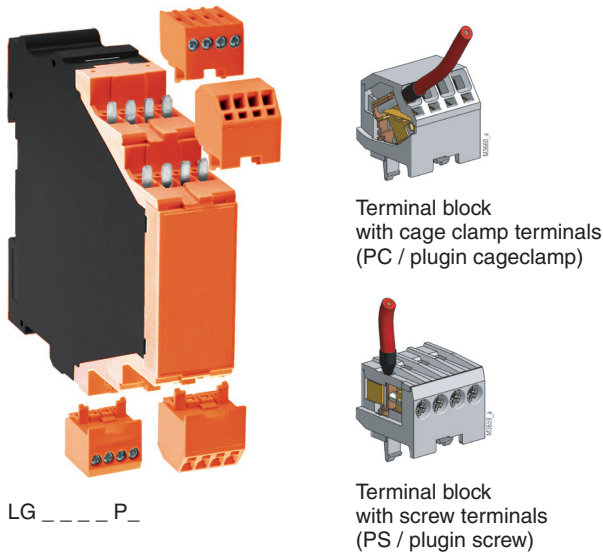

Approvals and marking



BG-valid to 30.06.009

* LH 5925 is a combination of 2 approved modules: LG 5925 and LG 5929

¹⁾ pending

Applications

- Protection of people and machines
- Emergency stop circuits on machines
 - Monitoring of safety gates

Notes

Removing the terminal blocks with cage clamp terminals

1. The unit has to be disconnected.
2. Insert a screwdriver in the side recess of the front plate.
3. Turn the screwdriver to the right and left.
4. Please note that the terminal blocks have to be mounted on the belonging plug in terminations.

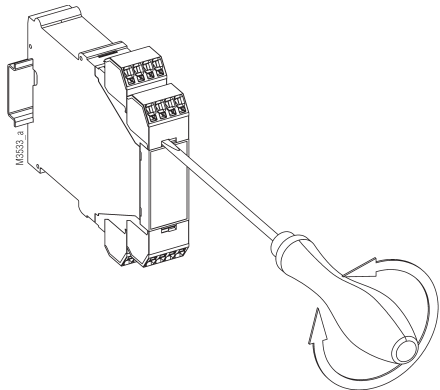

Indicators

- upper LED: on when supply connected
- LG 5925
lower LEDs: on when relay K1 and K2 energized
- LH 5925
lower LEDs: on when relay K1/K2 and K2/K4 energized

Function diagram

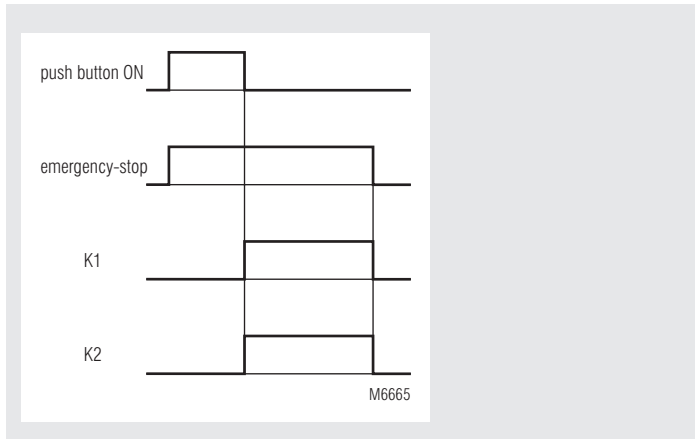

Circuit diagrams

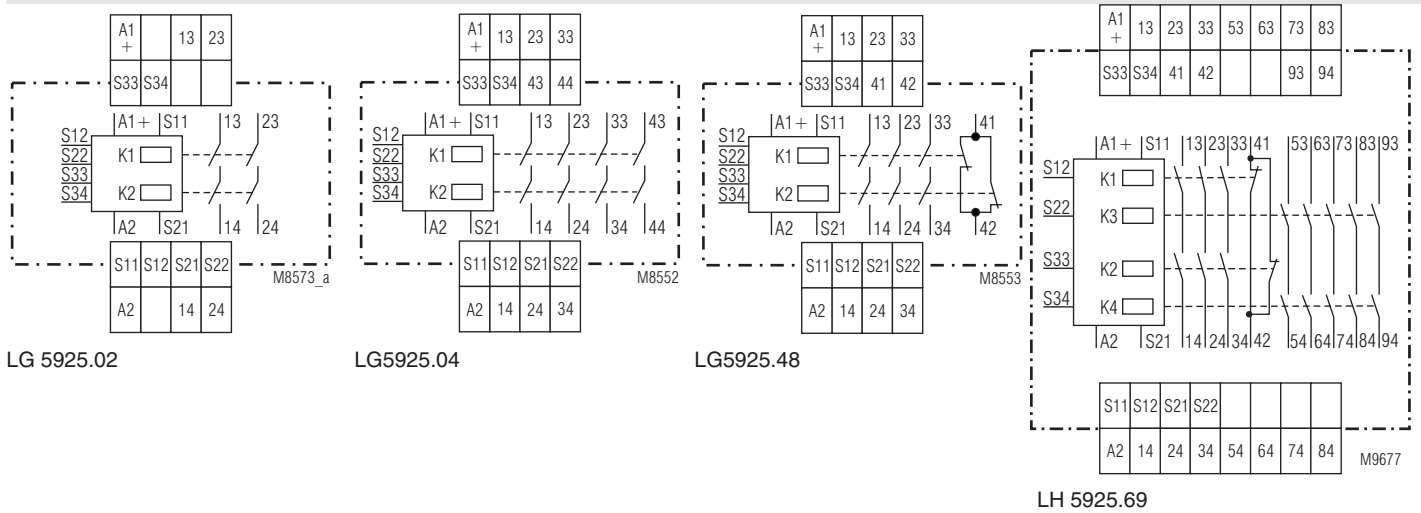

Block diagram

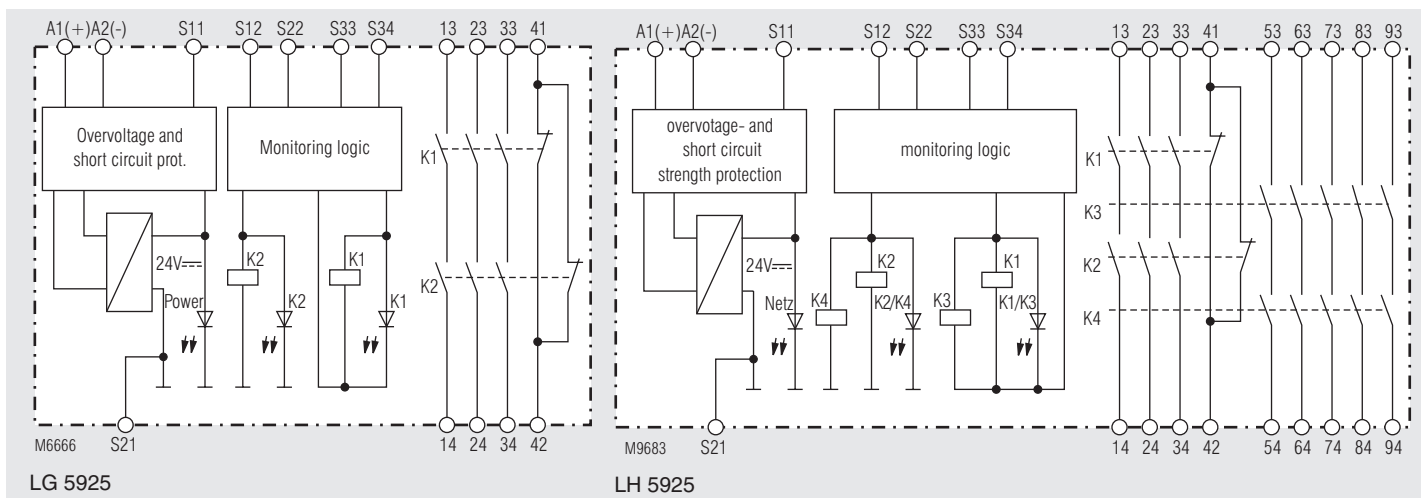

Setting

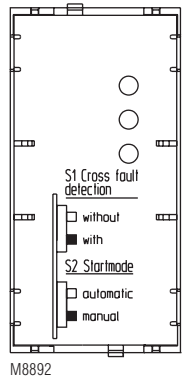
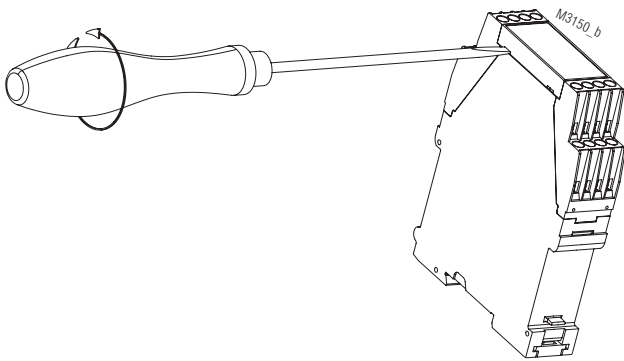

Disconnect unit before setting of S1
Drawing shows setting at the state of delivery

Notes

The category of a safety relevant part of a control circuit according to EN 954-1 can be different to the category 4 of the E-stop module LG 5925 depending on the external connections.
Line fault detection on On-button:
The line fault detection is only active when S12 and S22 are switched simultaneously. If The On-button is closed before S12, S22 is connected to voltage (also when line fault across On-Button), the output contacts will not close. A line fault across the On-button which occurred after activation of the relay, will be detected with the next activation and the output contacts will not close.
ATTENTION ! If a line fault occurs after the voltage has been connected to S12, S22, the unit will be activated because this line fault is similar to the normal On-function.

The terminal S21 permits the operation of the device in IT-systems with insulation monitoring, serves as a reference point for testing the control voltage and is used to connect the E-stop loop when cross fault monitoring is selected.

Connecting the terminal S21 to the protective ground bridges the internal short-circuit protection of Line A2 (-). The short-circuit protection of line A1 (+) remains active.
To alter the functions automatic start - manual start and with or without cross fault monitoring, the switches S1 and S2 are used. These are located behind the front cover (see unit programming).
The setting with or without cross fault monitoring on E-stop buttons is made with S1. S2 is used to change between automatic an manual restart. On automatic start also the terminals S33 - S34 have to be linked. For connection please see application examples.

ATTENTION - AUTOMATIC START!



According to IEC/EN 60 204-1 part 9.2.5.4.2 and 10.8.3 it is not allowed to restart automatically after emergency stop. Therefore the machine control has to disable the automatic start after emergency stop.

Technical Data

Input circuit

Nominal Voltage U_N :
LG 5925: AC/DC 24 V, AC 230 V
other voltages on request
AC/DC 24 V
LH 5925:

Voltage range
AC / DC
at 10% residual ripple:
AC: 0.9 ... 1.1 U_N
0.85 ... 1.1 U_N

Nominal consumption at U_N :
LG 5925: DC approx. 1.5 W
AC approx. 3.7 VA
LH 5925: DC approx. 3 W
AC approx. 4 VA

Min. Off-time:
Control voltage on S11 at U_N : DC 22 V at AC/DC units
DC 24 V at AC units

Control current typ. over S12, S22: 30 mA at U_N

Min. voltage on S12, S22 when relay activated: DC 20 V at AC/DC units
DC 19 V at AC units

Short-circuit protection: Internal PTC
Overvoltage protection: Internal VDR

Output

Contacts
LG 5925.02: 2 NO contacts
LG 5925.04: 4 NO contact
LG 5925.48: 3 NO, 1 NC contact
LH 5925.69: 8 NO, 1 NC contact
The NO contacts are safety contacts.
ATTENTION! The NC contacts 41-42 can only be used for monitoring.

Operate delay typ. at U_N :
Manual start: 30 ms
automatic start: 350 ms

Release delay typ. at U_N :
Disconnecting the supply: 150 ms at AC units
50 ms at DC units
130 ms at AC units
50 ms at DC units

Contact type: Relay positive guided
Nominal output voltage: AC 250 V
DC: see limit curve for arc-free operation
max. 8 A per contact
see current limit curve

Thermal current I_{th} : max. 8 A per contact
see current limit curve

Switching capacity
to AC 15:
NO contacts: 3 A / AC 230 V IEC/EN 60 947-5-1
NC contacts: 2 A / AC 230 V IEC/EN 60 947-5-1
to DC 13:
NO contacts: 4 A / DC 24 V IEC/EN 60 947-5-1
0.5 A / 110 V IEC/EN 60 947-5-1
NC contacts: 4 A / 24 V IEC/EN 60 947-5-1
to DC 13:
NO contacts: 8 A / 24 V > 25 x 10³
ON: 0.4 s, OFF: 9.6 s

Electrical contact life
to 5 A, AC 230 V $\cos \varphi = 1$: > 2.2 x 10⁵ switching cycles
Permissible operating frequency: max. 1 200 operating cycles / h
Short circuit strength
max. fuse rating: 10 A gL IEC/EN 60 947-5-1
line circuit breaker: B 6 A
Mechanical life: > 20 x 10⁶ switching cycles

Technical Data

General Data

Operating mode: Continuous operation
Temperature range: - 15 ... + 55 °C
Clearance and creepage distances
Rated impuls voltage / pollution degree: 4 kV / 2 IEC 60 664-1

EMC
Electrostatic discharge: 8 kV (air) IEC/EN 61 000-4-2
10 V / m IEC/EN 61 000-4-3
HF irradiation: 2 kV IEC/EN 61 000-4-4
Fast transients:
Surge voltages between

wires for power supply: 1 kV, 0.5 kV IEC/EN 61 000-4-5
24 V at AC/DC units
between wire and ground: 2 kV IEC/EN 61 000-4-5
Interference suppression: Limit value class B EN 55 011

Degree of protection
Housing: IP 40 IEC/EN 60 529
Terminals: IP 20 IEC/EN 60 529

Housing: Thermoplastic with V0 behaviour according to UL subject 94
Amplitude 0.35 mm IEC/EN 60 068-2-6
frequency 10 ... 55 Hz
15 / 055 / 04 IEC/EN 60 068-1
EN 50 005

Vibration resistance: EN 50 005
DIN 46 228-1/-2/-3/-4

Climate resistance:
Terminal designation:
Wire connection
Screw terminals (integrated): 1 x 4 mm² solid or
1 x 2.5 mm² stranded ferruled or
2 x 1.5 mm² stranded ferruled or
2 x 2.5 mm² solid

Insulation of wires or sleeve length: 8 mm
Plugin with screw terminals
max. cross section for connection: 1 x 2.5 mm² solid or
1 x 2.5 mm² stranded ferruled

Insulation of wires or sleeve length: 8 mm
Plugin with cage clamp terminals
max. cross section for connection: 1 x 4 mm² solid or
1 x 2.5 mm² stranded ferruled

min. cross section for connection: 0.5 mm²
Insulation of wires or sleeve length: 12 ±0.5 mm
Wire fixing: Plus-minus terminal screws M 3.5
box terminals with wire protection or cage clamp terminals
DIN rail IEC/EN 60 715

Mounting:
Weight:
LG 5925, AC/DC 24 V: 210 g
LG 5925, AC 230 V: 275 g
LH 5925, AC/DC 24 V: 375 g

Dimensions

Width x height x depth
LG 5925: 22.5 x 90 x 121 mm
LG 5925 PC: 22.5 x 111 x 121 mm
LG 5925 PS: 22.5 x 104 x 121 mm
LH 5925: 45 x 90 x 121 mm

Safety related data

Probability of dangerous Failure per Hour (PFH_D): 1.74 · 10⁻¹⁰ 1/h

Safe Failure Fraction (SFF): 99.7 %

Proof Test Intervall (T1): 20 years



The values stated above are valid for the standard type. Safety data for other variants are available on request

Standard type

LG 5925.48 AC/DC 24 V

Article number:

0056025

• Output: 3 NO contacts, 1 NC contact

• Nominal voltage U_N : AC/DC 24 V

• Width: 22.5 mm

Variant

LG 5925. __ / 60:

with CSA-approval

Ordering example for variants

L_ 5925 . _ _ /60 PS DC 24 V

Nominal voltage
Type of terminals
without indication: terminal blocks fixed, with screw terminals
PC (plugin cage clamp): plugable terminal blocks with cage clamp terminals
PS (plugin screw): plugable terminal blocks with screw terminals
Variant, if required
Contacts
G: Width 22.5 mm
H: Width 45 mm

Characteristics

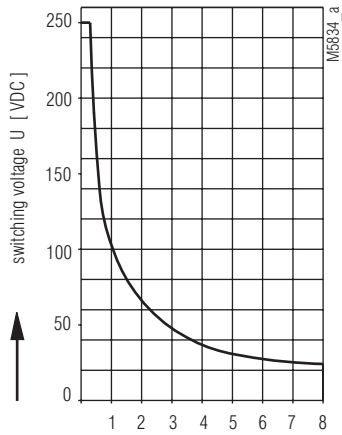

safe breaking, no continuous arcing, max. 1 switching cycle/s

Arc limit curve under resistive load

Characteristics

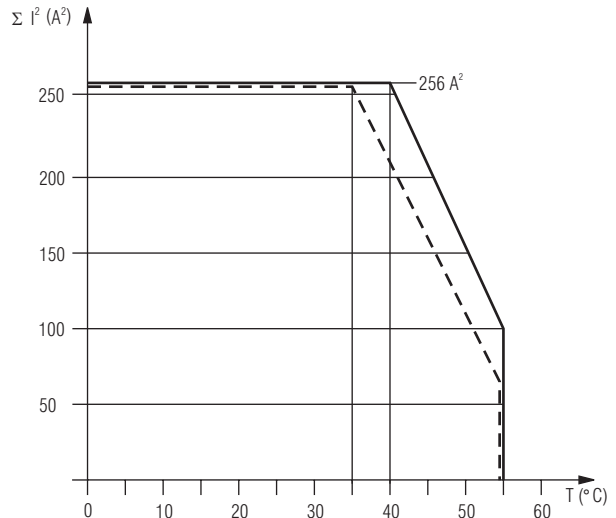

AC/DC 24V
Max. current at 55°C over
4 contact path = $5A \cong 4 \times 5^2 A^2 = 100A^2$

AC 230V
Max. current at 55°C over
4 contact path = $4A \cong 4 \times 4^2 A^2 = 64A^2$

$$\Sigma I^2 = I_1^2 + I_2^2 + I_3^2 + I_4^2$$

I_1, I_2, I_3, I_4 - current in contact paths

Total current limit curve LG 5925 (Mounted with distance, with air circulation)

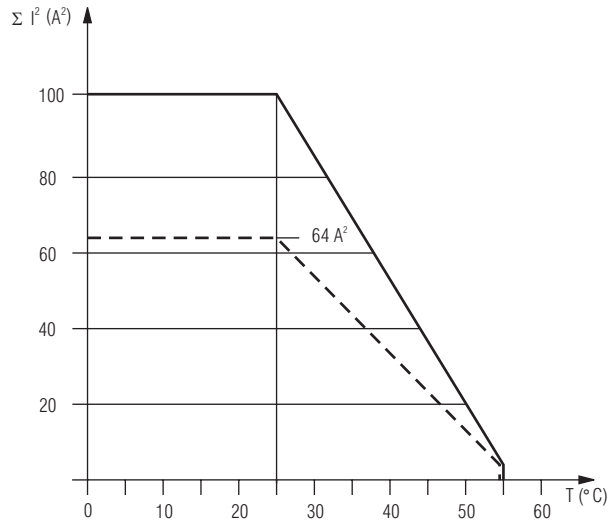

AC/DC 24V
Max. current at 55°C over
4 contact path = $1A \cong 4 \times 1^2 A^2 = 4A^2$

AC 230V
Max. current at 55°C over
4 contact path = $1A \cong 4 \times 1^2 A^2 = 4A^2$

$$\Sigma I^2 = I_1^2 + I_2^2 + I_3^2 + I_4^2$$

I_1, I_2, I_3, I_4 - current in contact paths

Total current limit curve LG 5925 (Mounted without distance, heated by units with simialr load)

Kennlinien

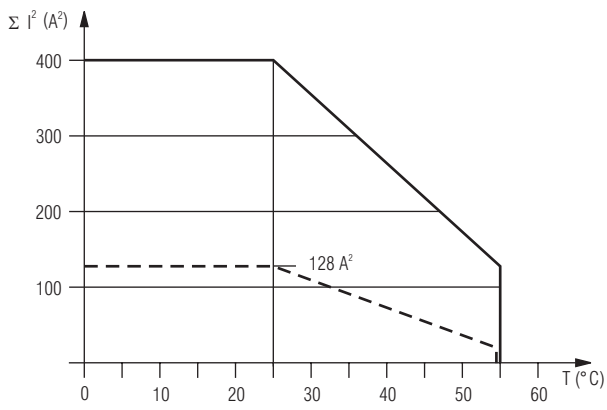

M9684_b

— device mounted on distance with air circulation.
max. current at 55°C over
8 contact path = $4A \hat{=} 8 \times 4^2 A^2 = 128 A^2$

- - - device mounted without distance heated by
devices with same load,
Max. current at 55°C over
8 contact path = $2A \hat{=} 8 \times 2^2 A^2 = 32 A^2$

Quadratic total current

$$\Sigma I^2 = I_1^2 + I_2^2 + I_3^2 + I_4^2 + I_5^2 + I_6^2 + I_7^2 + I_8^2$$

$I_1, I_2, I_3, I_4, I_5, I_6, I_7, I_8$ - current in contact paths

Total current limit curve LH 5925

Application examples

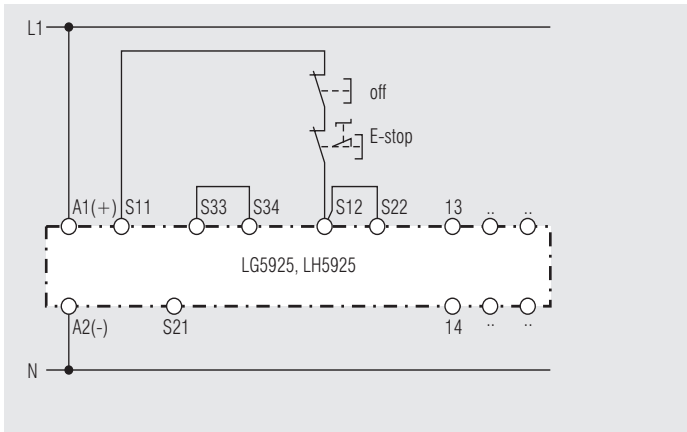

Single channel emergency stop circuit. This circuit does not have any redundancy in the emergency-stop control circuit.

Note: Refer to "Unit programming"!

Switches in pos.: S1 no cross fault detection
S2 automatic start

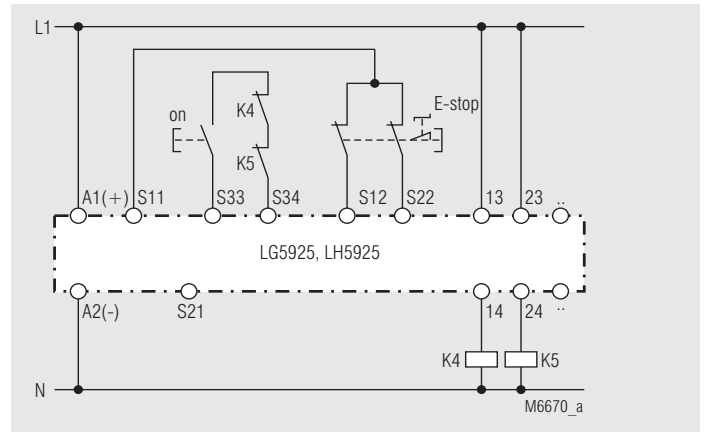

Contact reinforcement by external contactors, 2-channel controlled.

The output contacts can be reinforced by external contactors with positive guided contacts for switching currents > 8 A.

Functioning of the external contactors is monitored by looping the NC contacts into the closing circuit (terminals S33-S34).

Note: Refer to "Unit programming"!

Switches in pos.: S1 no cross fault detection
S2 manual start

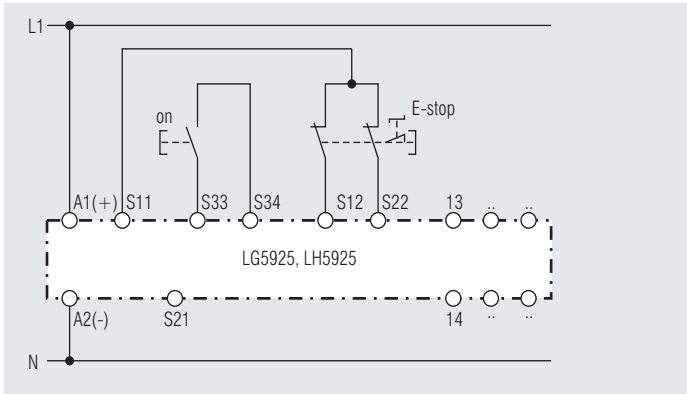

2-channel emergency stop circuit without cross fault monitoring.

Note: Refer to "Unit programming"!

Switches in pos.: S1 no cross fault detection
S2 manual start

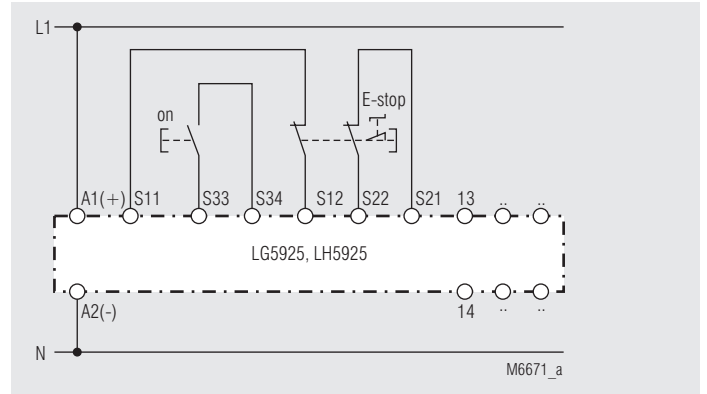

2-channel emergency stop circuit with cross fault detection

Note: Refer to "Unit programming"!

Switches in pos.: S1 cross fault detection
S2 manual start

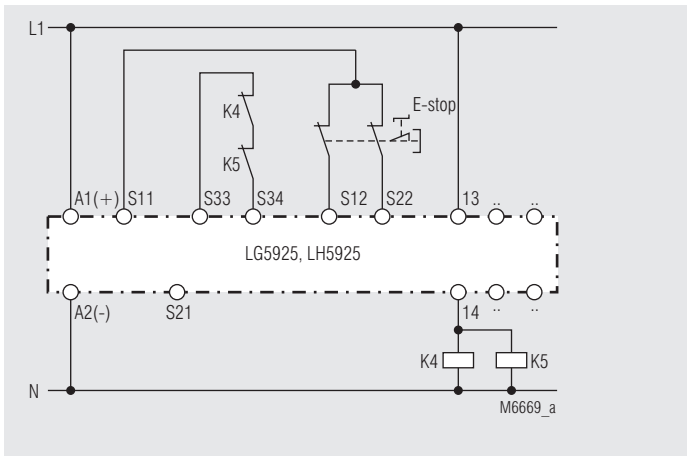

Contact reinforcement by external contactors controlled by one contact path.

Note: Refer to "Unit programming"!

Switches in pos.: S1 no cross fault detection
S2 automatic start

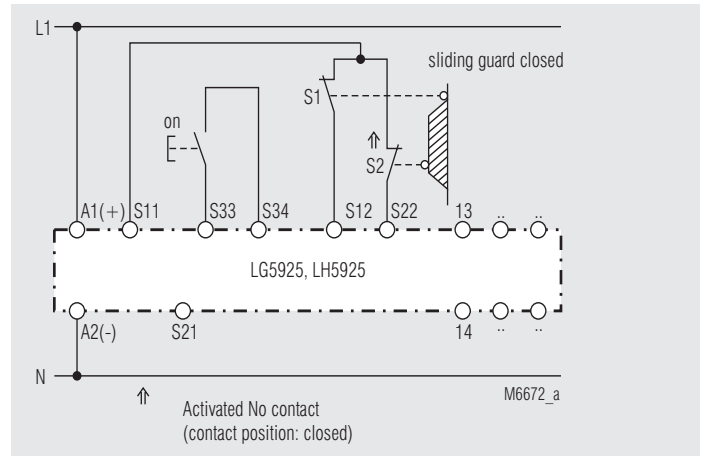

2-channel safety gate monitoring.

Note: Refer to "Unit programming"!

Switches in pos.: S1 no cross fault detection
S2 manual start