

**Input module IP 5502
for CANopen**

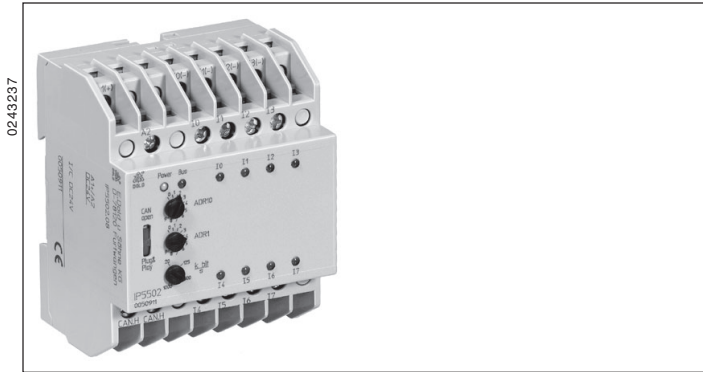

0243237

- According to IEC/EN 61 131-2, IEC/EN 50 178
- CANopen interface according to DS301 version 3.0 (Plug and Play selectable), as option with galvanic separation
- 8 digital inputs for DC 24 V
- LED indicators for supply voltage and Bus status
- 70 mm width

Circuit diagram

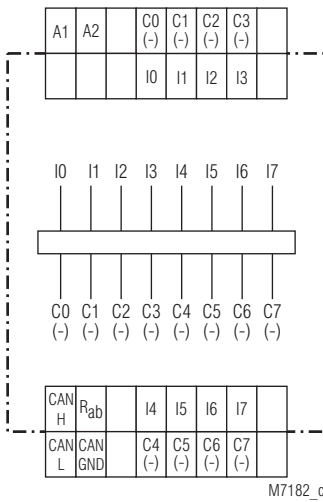

M7182_c

IP 5502.08

Additional information

- Datasheet minimaster DX 5504
- Datasheet input module IP 5502
- Datasheet output module IP 5503
- Datasheet emergency off monitor BH 5922
- Datasheet minimaster IL 5504, IN 5504
- Datasheet power supply IR 5592
- Datasheet analogue input module IL 5508
- Datasheet analogue output module IL 5507

Approvals and marking



Application

The digital input module IP 5502 collects signals of a control circuit from limit switches, push buttons, sensors etc. The modules are used in industrial control circuits and building automation.

Indicators

- yellow LED "Power": on, when supply connected
- yellow LED "BUS": on, when bus is active
- green LEDs I₀ ... I₇: on, when input signal applied

Setting and adjustment

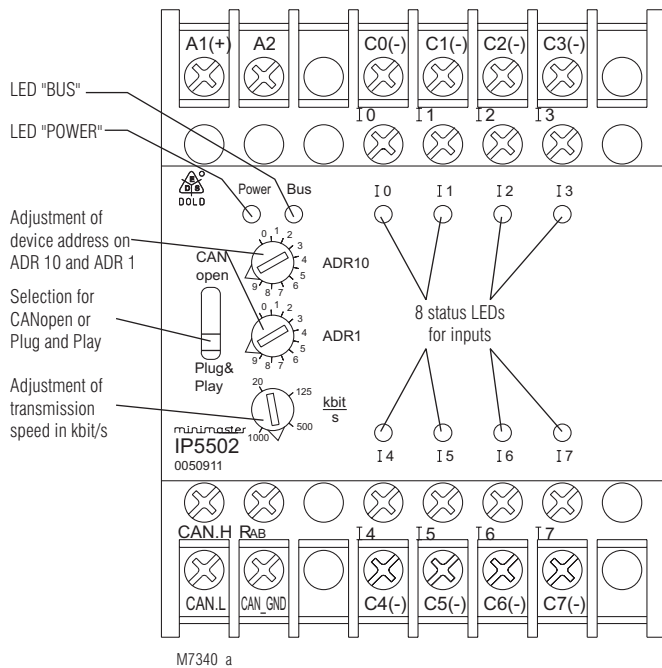

M7340_a

CANopen operation

With switch in position "CANopen" the CAN bus runs the CANopen protocol. The configuration is made with the programming software PN 5501 in conjunction with minimaster IL 5504 / IN 5504 or e.g. with ProCANopen. The corresponding configuration file on CD can be ordered under order no. PN 5501, article no. 0052860

Plug and Play operation

With switch in position "Plug and Play" the CANopen bus runs a variant of the CANopen protocol and allows only to operate Dold modules that have this feature. If a system is configured in Plug and Play operation, it can be altered to CANopen at any time.

Address setting in Plug and Play mode

To allow the input module to communicate via CAN-bus with a corresponding device, the address has to be adjusted on the 2 rotational switches on the front see below: The addresses 1 ... 49 and 51 ... 99 can be chosen. In Plug and Play mode the addresses 0 and 50 do not exist.

Input module IP 5502 with address	transmits to	Output module IP 5503 with address
1	→	51
.		.
49	→	99

Example of setting:
Upper rotational switch "ADR 10": address 14 in position 1
Lower rotational switch "ADR 1": in position 4

Setting and adjustment

Set-up procedure

- 1.) Connect device to CANopen-bus
- 2.) Terminate bus on both ends with bridge between CAN-H and R_{ab} on first and last module.
- 3.) Adjust transmission speed (e. g. 20 K bit / s)
- 4.) Adjust device addresses

Attention:



To allow transmission in Plug and Play mode, one of the input modules e.g. IP 5502 of the CAN-bus has to be set to address 1.

Technical data

Auxiliary voltage

Auxiliary voltage U_H A1/A2: DC 24 V
Voltage range: 0,8 ... 1,1 U_N
Nominal consumption: 0,5 W DC 24 V

Input

Inputs galvanic separated
IP 5502: 8 digital inputs IEC/EN 61 131-2
Input voltage: DC 24 V

CANopen interface

IP 5502.08/100: galvanic separation according to ISO 11 898-1
Wire: screened twisted pair
Transmission speed: adjustable 20 K bit/s, 125 K bit/s, 500 K bit/s, 1 M bit/s,
max. length: 20 K bit/s = 2.500 m
125 K bit/s = 500 m
500 K bit/s = 100 m
1 M bit /s = 25 m

Plug and Play

Transmission speed: 20 K bit / s (recommended)

Attention:



Both ends of the 2-wire bus have to be terminated with a bridge between CAN_H and R_{ab}.

General data

Operating mode: Continuous operation
Temperature range: - 20 ... + 60°C
Clearance and creepage distances
overvoltage category / pollution degree: 4 kV / 2 IEC 60 664-1
EMC
Electrostatic discharge: 8 kV (air) IEC/EN 61 000-4-2
HF-irradiation: 10 V / m IEC/EN 61 000-4-3
Fast transients: 2 kV IEC/EN 61 000-4-4
Surge voltages between wires for power supply: 1 kV IEC/EN 61 000-4-5
between wire and ground: 2 kV IEC/EN 61 000-4-5
Interference suppression: Limit value class B EN 55 011
Degree of protection
Housing: IP 40 IEC/EN 60 529
Terminals: IP 20 IEC/EN 60 529
Housing: Thermoplastic with V0-behaviour according to UL subject 94
Vibration resistance: amplitude 0,35 mm
frequency 10 ... 55 Hz IEC/EN 60 068-2-6
Climate resistance: 20 / 060 / 04 IEC/EN 60 068-1
Terminal designation: EN 50 005
Wire connection: 2 x 2,5 mm² solid or 2 x 1,5 mm² stranded wire with sleeve
DIN 46 228-1/-2/-3/-4
Wire fixing: Flat terminals with self-lifting clamping peace IEC/EN 60 999-1
DIN rail IEC/EN 60 715
Mounting:
Weight: 187 g

Technical data

Dimensions

Width x height x depth: 70 x 90 x 61 mm

Standard type

IP 5502.08 DC 24 V
Article number: 0050911
• 8 digital inputs
• Nominal voltage U_N: DC 24 V
• Width: 70 mm

Variant

Ordering example for variant

IP 5502.08/_00 DC 24 V
└──────────┬────────── Bus interface
0 CANopen interface without galvanic separation
1 CANopen interface with galvanic separation

Accessories

- CANopen PLC IL 5504
- CANopen PLC DX 5504 (IP 67)
- Input / Output module IN 5509
- Input module, analogue / digital DX 5509 (IP67)
- Input module, digital IP 5502
- Output module, digital IP 5503
- Input module, analogue IL 5508
- Output module, analogue IL 5507

Application examples

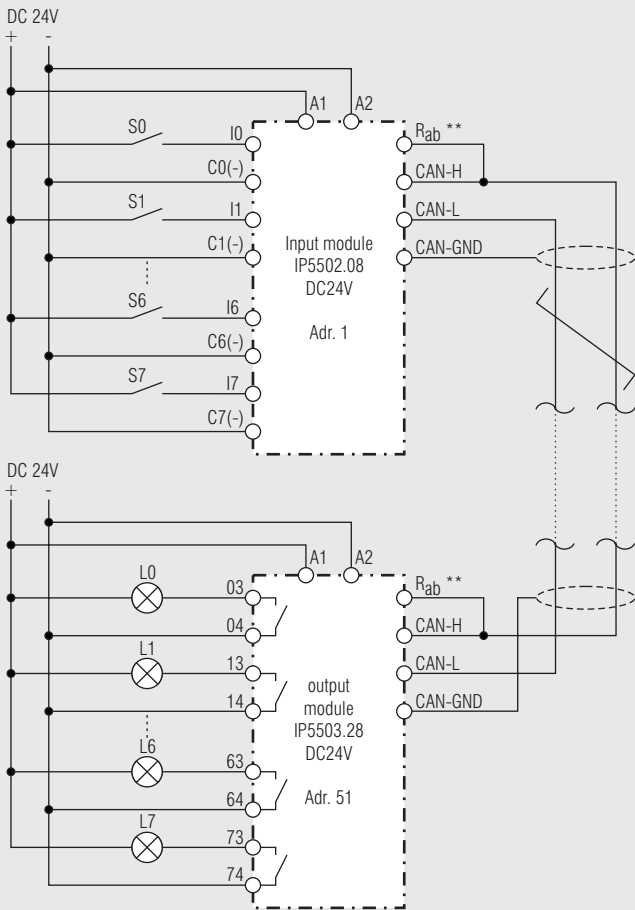

** Both ends of the 2-wire bus have to be terminated with a bridge between CAN-H and R_{ab}.

M7329_a

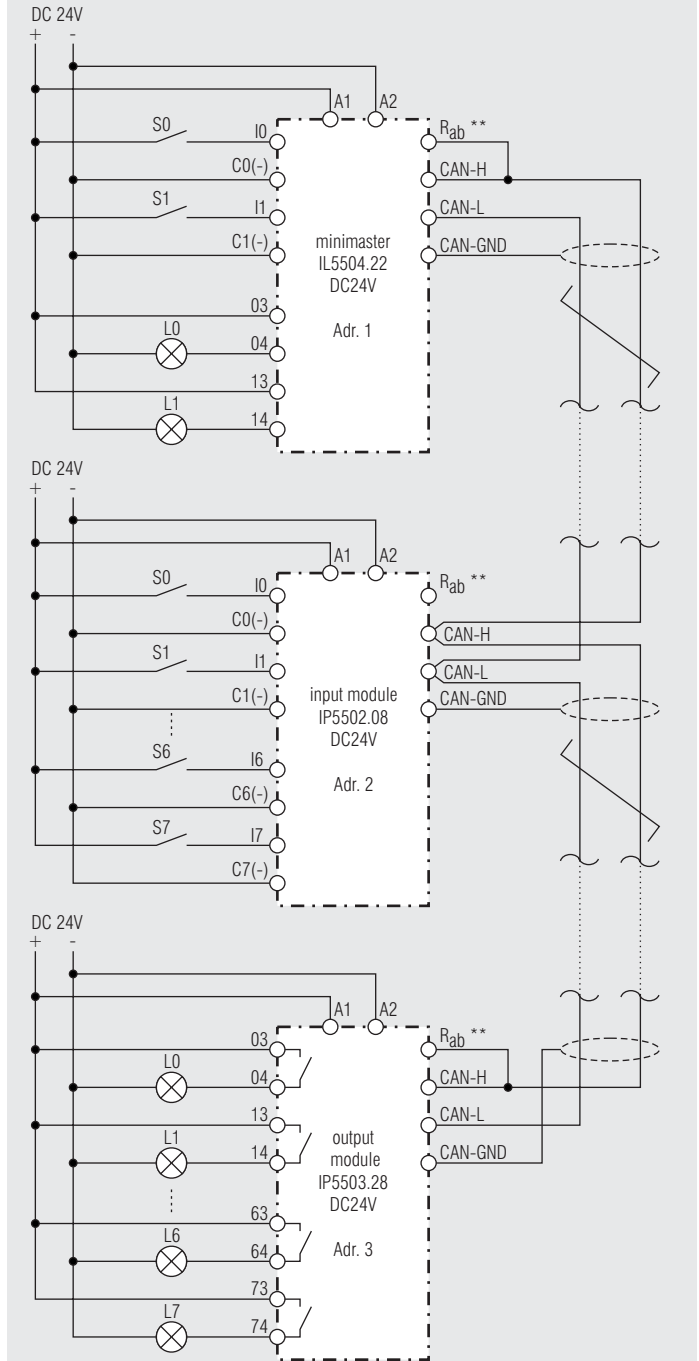

** Both ends of the 2-wire bus have to be terminated with a bridge between CAN-H and R_{ab}.

M7853_d

Design of a 2-wire remote control is very simple:
Connect input module IP 5502 to output module IP 5503 via a 2-wire line adjust addresses and speed ... ready to go.

Application example

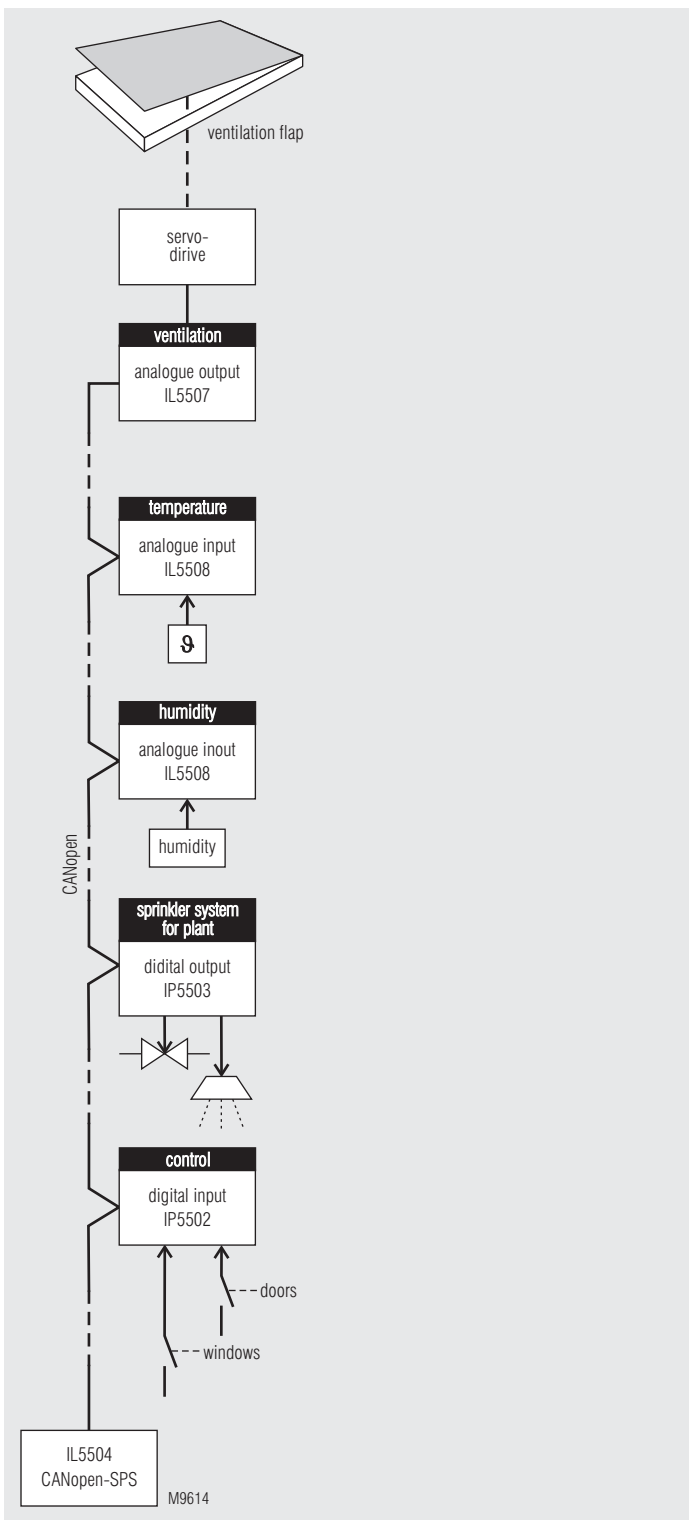

CANopen-application for greenhouses:
dependend on temperature- and humidity ventilation flap applications
and sprinkler systems for plants in a greenhouse.