

Speed or Standstill Monitor BH 5932 SAFEMASTER®

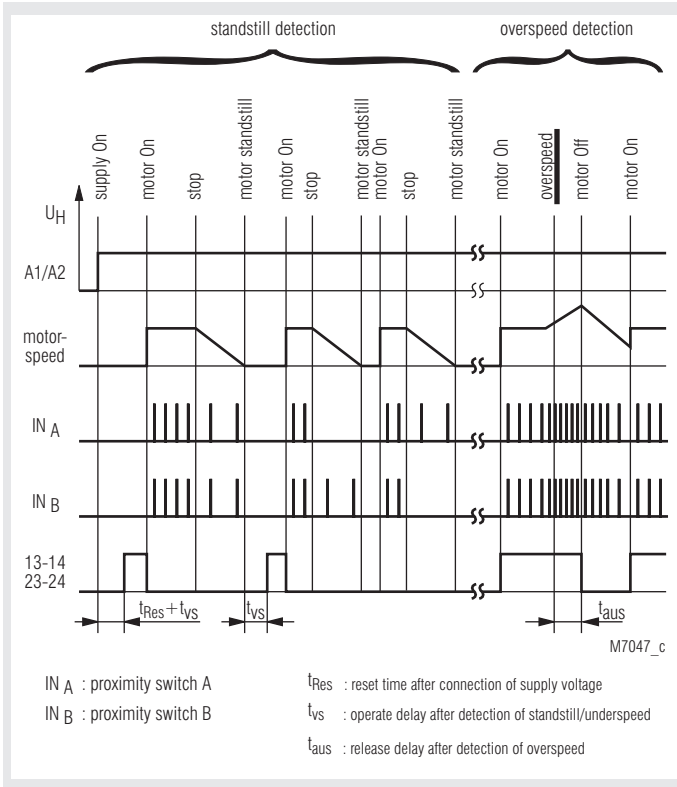

Function diagram



- According to
 - SIL Claimed Level (SIL CL) 3 to EN 62061
 - Performance Level (PL) e / cat. 3 to DIN EN ISO 13849-1
- For stop category 0 according to EN 418
- 2-channel input
- To monitor rotation and linear movement
- PNP proximity sensor inputs
- Optionally inputs for NPN proximity sensors
- Monitoring of connected sensor
- Fixed setting, adjustable as option
- Energised when speed is under setting value
- LED indication
- Feedback circuit X1 - X2 to monitor external contacts
- Positive guided contacts
- 2 NO, 1 NC contact
- Wire connection: also 2 x 1.5 mm² stranded ferruled (isolated), DIN 46 228-1/-2/-3/-4 or 2 x 2.5 mm² stranded ferruled DIN 46 228-1/-2/-3
- Width 45 mm

Approvals and marking



* see variants

Applications

Monitoring of speed or standstill also during setup operation

Indication

Standstill monitoring:

1. green LED: on, when supply voltage connected
2. green LED: on, when standstill detected on channel 1
3. green LED: on, when standstill detected on channel 2

Overspeed monitoring:

1. green LED: on, when supply voltage connected
2. green LED: on, when no overspeed detected on channel 1
3. green LED: on, when no overspeed detected on channel 2

Block diagram

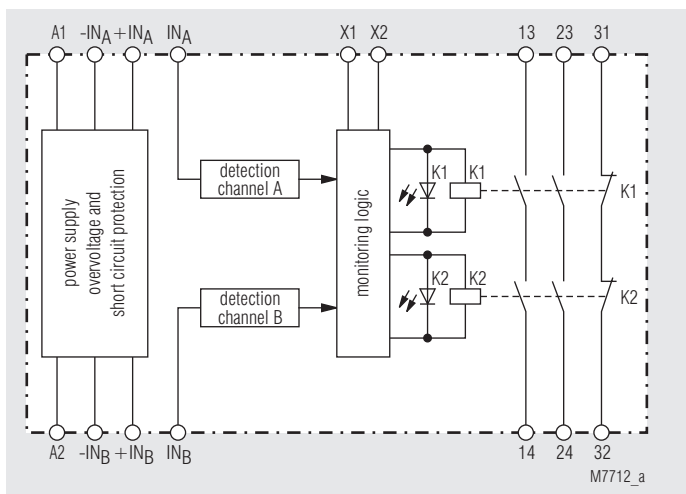

Circuit diagram

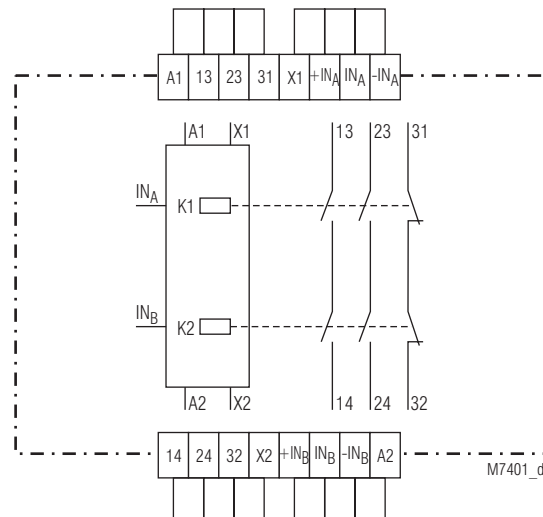

Unit setting

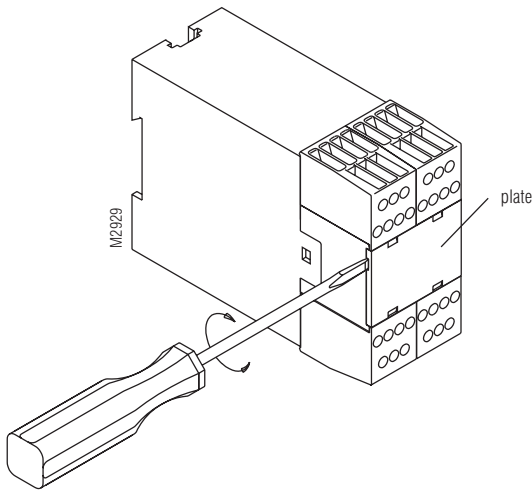

Model with separate adjustable channels

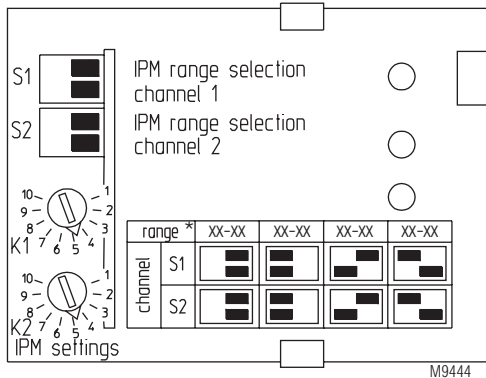

M9444

range* : 8-60 / 60-450 / 450-3600 / 1800-14000 lpm
or 20-110 / 120-900 / 950-7000 / 3700-26000 lpm

Only operate switches while unit is disconnected

Model with common setting for both input channels and fine tuning to synchronise both channels

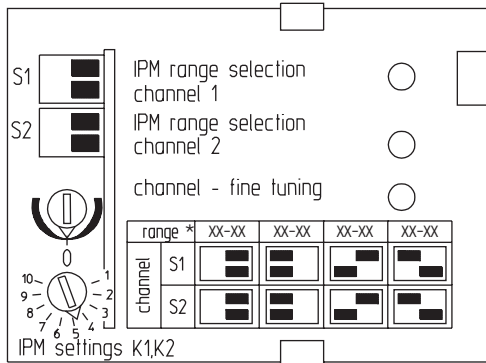

M9445

range* : 5-40 / 35-340 / 300-2700 / 1200-10500 lpm
or 10-80 / 80-650 / 600-5300 / 2400-20000 lpm

Only operate switches while unit is disconnected

Notes

The device can be used for standstill and speed monitoring. All units have 2 sensing channels.

Variants

Three main variants are available:

1. Devices with fixed tripping value
2. Devices with separate adjustment for both channels
3. Devices with common adjustment for both channels and fine tuning to synchronise both channels

Setting ranges

On adjustable units the total range is split up in 4 sub ranges that can be selected with 2 DIP-switches per channel. To adjust the setting value in the selected range the potentiometers are used.

Adjustment of setting range

The number of pulses [lpm] to be adjusted can be calculated using the following formula:

$$\text{Rpm} \times \text{number of sensing spots} = \text{lpm}$$

$$\text{e.g. } 7.5 \text{ Rpm} \times 2 \text{ sensing spots} = 15 \text{ lpm}$$

Operation as standstill monitor

Both channels must be adjusted so that they switch simultaneously. The maximum time after standstill detection until switching of the output relays is depending on the adjusted lpm value. This delay can be calculated as follows:

$$\frac{60 \text{ s}}{\text{adjusted lpm-value}} + 2.5 \text{ s} = t_{vs}$$

$$t_{vs} \hat{=} \text{operate delay after standstill detection}$$

$$\text{e.g. at a setting of } 15 \text{ lpm}$$

$$\frac{60 \text{ s}}{15} + 2.5 \text{ s} = 6.5 \text{ s}$$

Operation as overspeed monitor

Especially on overspeed monitoring it is necessary to adjust both channels precisely on simultaneous switching. If the two channels switch not at the same time the disconnection of the drive is only made with the faster channel. The speed can drop immediately so that the slower channel does not detect overspeed and remains switched on. A new start is then disabled and the relay does not switch on again. A restart is only possible by disconnecting the power supply. To achieve an accurate setting the lpm setting value should be in the middle part of the setting range. The adjustment of simultaneous switching is easier on units with separate setting for each channel as on units with fine tuning potentiometer.

Proximity sensors

For safe operation the proximity sensors should be mounted vibration free. The position of the sensors should be chosen in a way that both sensors are operated simultaneously. Care must be taken that the sensors do not influence each other. The connection of the sensors to the supply is monitored. If there is an interruption in the sensor supply the corresponding output relay cannot be switched on, or if it is already on, it will switch off immediately. To achieve a fault free operation, the sensor must have draw at least 3 mA in off state. If sensors with lower consumption are used only devices without sensor detection can be operated. According to EN 954-1 the sensors must be checked for correct function in reasonable time intervals.

Feedback circuit, reset, LEDs and timing

The reset circuit X1 - X2 must be closed before connecting the power supply. The unit is ready for operation after typically 1.5 sec after the supply is connected.

The LEDs channel 1 and channel 2 are on when the corresponding relay is energised. The output contacts of the relays will only be activated if both input channels reach the enabling condition within a time span of approx. 2 sec. If the response value is not reached on both channels within this time, e.g. because of a defective sensor or because the sensors do not simultaneously switch the output contacts are not enabled.

Technical Data

Input

Nominal voltage U_N:	AC/DC 24 V AC 110, 230 V
Voltage range	
AC:	0.85 ... 1.1 U_N
DC:	0.9 ... 1.1 U_N
Nominal consumption:	ca. 4 VA, 2.5 W
Nominal frequency	50 / 60 Hz
Frequency range:	45 ... 65 Hz
Start up reset time t_{Res}:	1.5 s
Hysteresis:	typ. 6 %

Inputs for NPN- or optional PNP proximity sensors

Input voltage:	DC 24 V
Input current:	max. 25 mA (per channel)
Min. current of sensor	3 mA
Min. pulse time:	1 ms On, 1 ms Off
Max. lpm at inputs	
IN_A und IN_B:	30000 lpm

Speed ranges [lpm]

Devices with fixed setting of speed

BH 5932/100, BH 5932/110:	15 / 30 / 60 / 120 lpm, fixed others on request (the output contacts close, when the speed is under the fixed lpm values)
Operate delay at standstill:	see formula
Release delay on overspeed:	t_{aus} = typ. 700 ms

Devices with separated adjustable channels

BH 5932/102, BH 5932/112	
Range 8 ... 14000 lpm:	adjustable in 4 subranges 8 ... 60, 60 ... 450, 450 ... 3600, 1800 ... 14000 lpm
or	
range 20 ... 26000 lpm:	adjustable in 4 subranges 20 ... 110, 120 ... 900, 950 ... 7000, 3700 ... 26000 lpm
Operate delay at standstill:	see formula
Release delay on overspeed	
Range 8 ... 14000:	t_{off} = typ. 700 ms
Range 20 ... 26000:	t_{off} = typ. 350 ms

Devices with fine tuning of simultaneity

BH 5932/103, BH 5932/113	
Range 5 ... 10500 lpm:	adjustable in 4 subranges 5 ... 40, 35 ... 340, 300 ... 2700, 1200 ... 10500 lpm
or	
range 10 ... 20000 lpm:	adjustable in 4 subranges 10 ... 80, 80 ... 650, 600 ... 5300, 2400 ... 20000 lpm
Operate delay at standstill:	see formula
Release delay on overspeed	
Range 5 ... 10500:	t_{off} = typ. 700 ms
Range 10 ... 20000:	t_{off} = typ. 350 ms

Output

Contacts:	2 NO, 1 NC
Contact type:	Positive guided
Thermal current I_{th}:	4 A
Switching current:	AC: 8 A cos φ 1 ... 0.7
Switching capacity to AC 15	3 A / AC 230 V for NO contact 2 A / AC 230 V for NC contact IEC/EN 60 947-5-1

Elektrical life

to AC 15 at 2 A, AC 230 V:	$\geq 3 \times 10^5$ switching cycles IEC/EN 60 947-5-1
----------------------------	--

Short-circuit strength

max. fuse rating:	4 A gL IEC/EN 60 947-5-1
Mechanical life:	$\geq 50 \times 10^6$ switching cycles

Technical Data

General Data

Operating mode:	Continuous operation	
Temperature range:	- 25 ... + 60 °C	
Clearance and creepage distances		
rated impuls voltage / pollution degree		IEC 60 664-1
Input / output	4 kV / 2	
EMC		
Electrostatic discharge:	8 kV (Air)	IEC/EN 61 000-4-2
HF irradiation:	10 V/m	IEC/EN 61 000-4-3
Fast transients:	2 kV	IEC/EN 61 000-4-4
Surge voltages		
between wires for power supply:	1 kV	IEC/EN 61 000-4-5
between wire and ground:	2 kV	IEC/EN 61 000-4-5
HF-wire guided:	10 V	IEC/EN 61 000-4-6
Interference suppression:	Limit class B	EN 55 011
Degree of protection		
Housing:	IP 40	IEC/EN 60 529
Terminals:	IP 20	IEC/EN 60 529
Housing:	Thermoplastic with V0 behaviour according to UL subject 94	
Vibration resistance:	Amplitude 0.35 mm frequency 10 ... 55 Hz	IEC/EN 60 068-2-6 IEC/EN 60 068-1
Climate resistance:	20 / 060 / 04	IEC/EN 60 068-1
Terminal designation:	EN 50 005	
Wire connection:	1 x 4 mm ² solid or 1 x 2.5 mm ² stranded ferruled (isolated) or 2 x 1.5 mm ² stranded ferruled (isolated) DIN 46 228-1/-2/-3/-4 or 2 x 2.5 mm ² stranded ferruled DIN 46 228-1/-2/-3	
Wire fixing:	Plus-minus terminal screws M3.5 box terminals with wire protection	
Mounting:	DIN rail	IEC/EN 60 715
Weight:	410 g	

Dimensions

Width x height x depth:	45 x 85 x 121 mm
--------------------------------	------------------

Safety related data

Probability of dangerous

Failure per Hour (PFH_D)	
BH5932/ __ 0:	$2.68 \cdot 10^{-9}$ 1/h
BH5932/ __ 1, BH5932/ __ 2:	$3.16 \cdot 10^{-9}$ 1/h
BH5932/ __ 3:	$3.25 \cdot 10^{-9}$ 1/h

Safe Failure Fraction (SFF)

BH5932/ __ 0:	97.6 %
BH5932/ __ 1, BH5932/ __ 2:	97.5 %
BH5932/ __ 3:	97.5 %

Proof Test Intervall (T1)

BH 5932/ __ 0; BH 5932/ __ 1 BH5932/ __ 2; BH5932/ __ 3:	20 Years
---	----------

Standard type

- BH 5932.22/112 AC/DC 24 V 20 ... 26000 lpm
Article number: 0059482
- BH 5932.22/112 AC/DC 24 V 8 ... 14000 lpm
Article number: 0059478
- Output: 2 NO, 1 NC contacts
- Nominal voltage U_N : DC 24 V
- Input: for pnp-sensors and with sensor detection
- Width: 45 mm

Variants

BH 5932.22/_/_/_/61: with UL-approval (Canada/USA)

Variants

Ordering example for variants

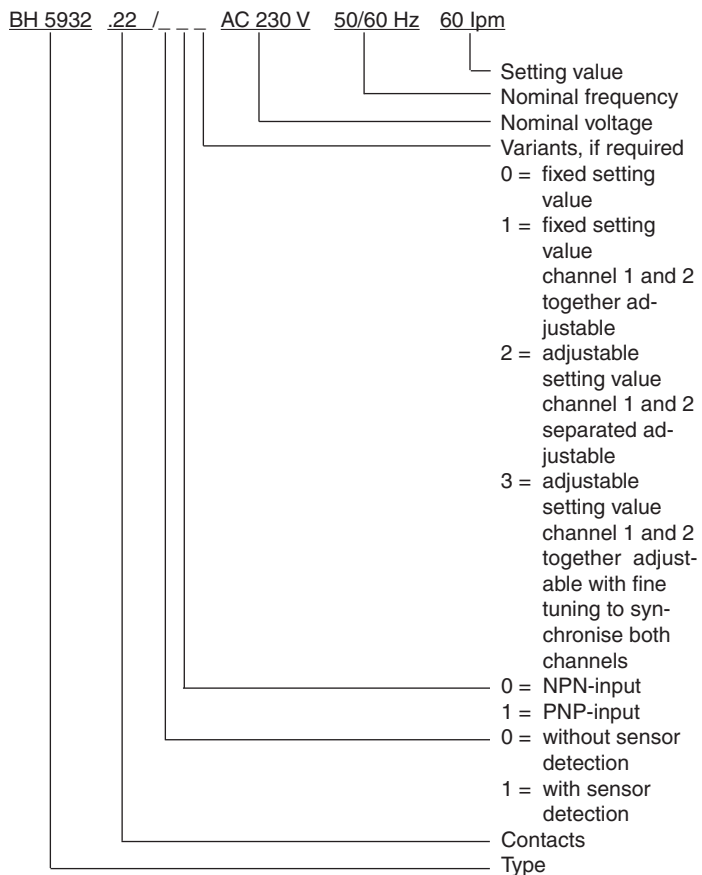

Connection examples

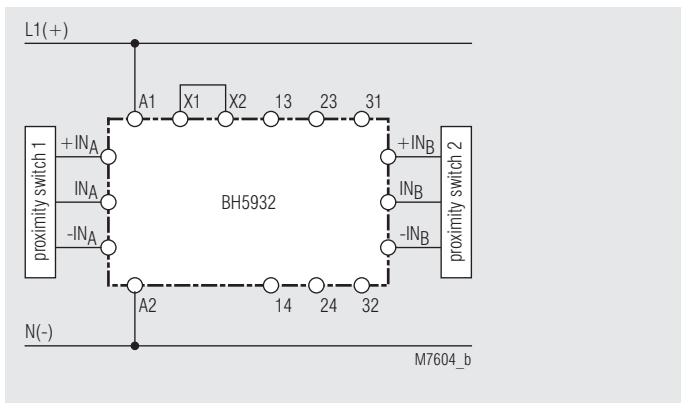

Standard connection

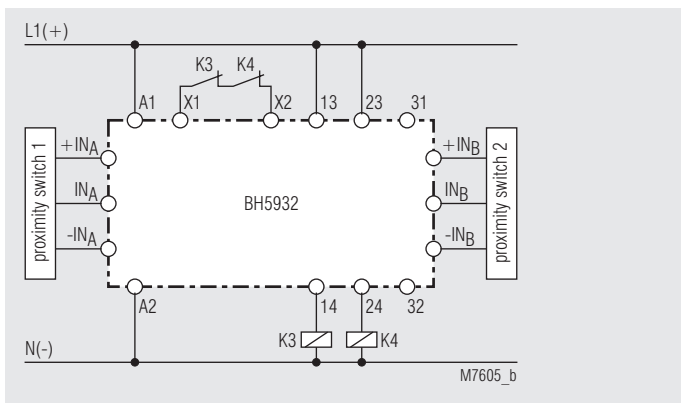

Connection with external contactors

Application example

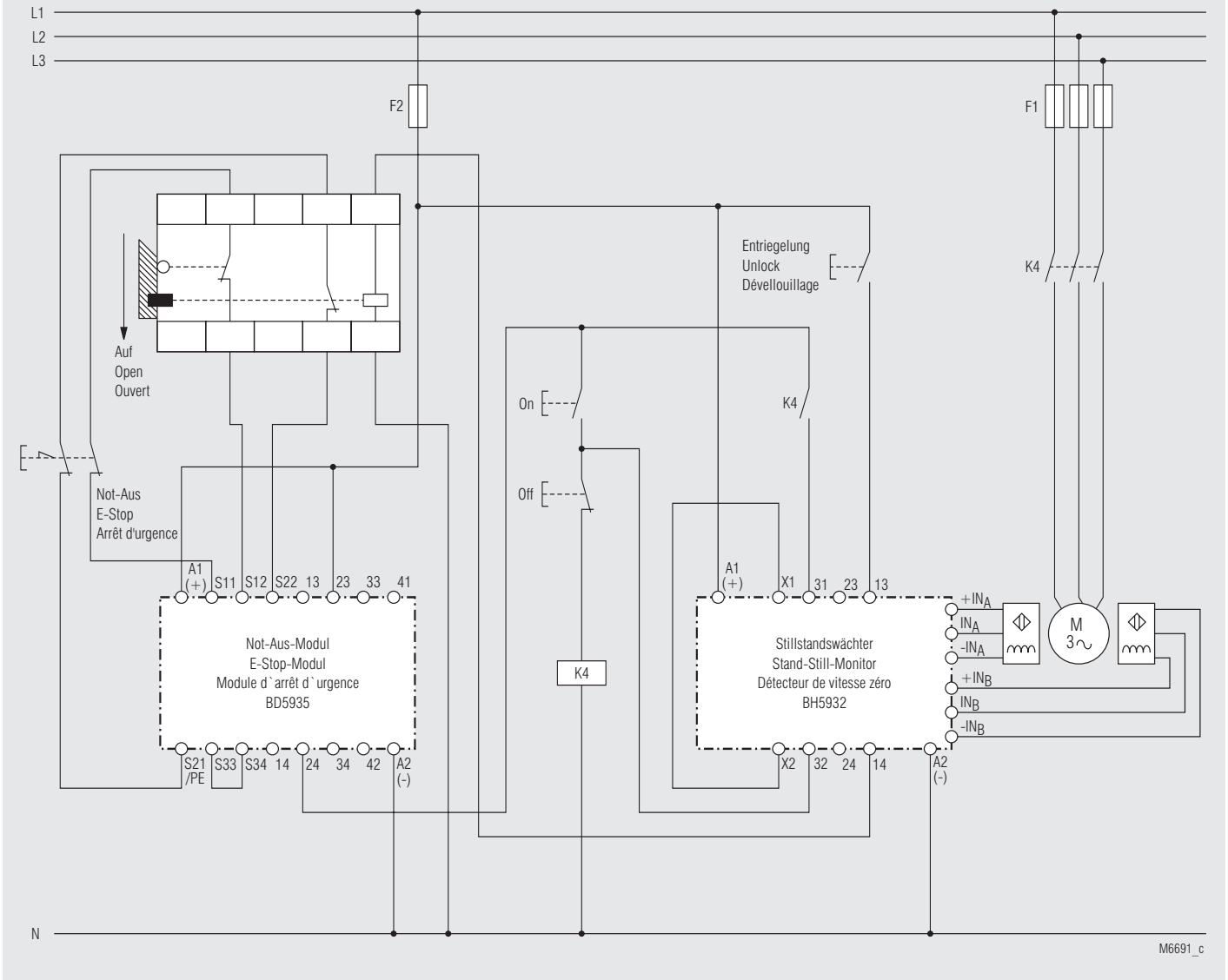

Initiators (proximity sensors), induktive

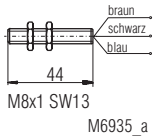
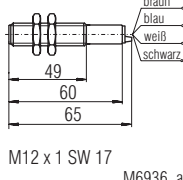
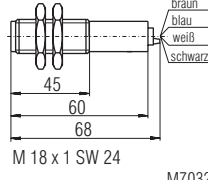
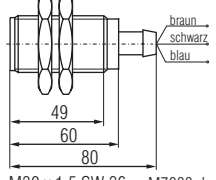
Type	NA 5001.01.10 pnp NA 5001.01.20 npn	NA 5002.01.34 pnp/npn	NA 5005.01.34 pnp/npn	NA 5010.01.10 pnp NA 5010.01.20 npn
Dimensions	 M8x1 SW13 M6935_a	 M12 x 1 SW 17 M6936_a	 M 18 x 1 SW 24 M7032_a	 M30 x 1,5 SW 36 M7033_b
Enclosure	Metal	Metal	Metal	Metal
Switching distance S_n	1 mm	2 mm	5 mm	10 mm
Switching frequency	5 000 Hz	1 000 Hz	300 Hz	200 Hz
Hysteresis	2 ... 10 %			
Repeat accuracy	5 %			
Voltage range	10 ... 30 V			
Residual ripple	< 10 %			
Continuous current	≤ 200 mA	≤ 100 mA	≤ 100 mA	≤ 400 mA
Output	.10 pnp NO .20 npn NO	.34 pnp NO + npn NO	.34 pnp NO + npn NO	.10 pnp NO .20 npn NO
Indication of output state	LED			
Ambient temperature	- 25 ... 70°C			
Temperature influence	10 %			
Degree of protection	IP 67			
Connection wire	2 m			
Fixing torque	4 Nm	15 Nm	40 Nm	100 Nm
Weight	45 g	70 g	120 g	270 g

Connection table BH 5932, BH 5932 / 00_

Type	Wire	Terminal on BH 5932
NA 5001.01.20	brown +	+ 24 V
	blue -	0 V
	black NO	I_{n_A} / I_{n_B}
NA 5002.01.34 NA 5005.01.34	brown +	+ 24 V
	blanc NO	I_{n_A} / I_{n_B}
	blue -	0 V
	black -	0 V
NA 5010.01.20	brown +	+ 24 V
	blue -	0 V
	black NO	I_{n_A} / I_{n_B}

Connection table BH 5932, BH 5932 / 01_

Type	Wire	Terminal on BH 5932
NA 5001.01.10	brown +	+ 24 V
	blue -	0 V
	black NO	I_{n_A} / I_{n_B}
NA 5002.01.34 NA 5005.01.34	brown +	+ 24 V
	blanc NO	+ 24 V
	blue -	0 V
	black -	I_{n_A} / I_{n_B}
NA 5010.01.10	brown +	+ 24 V
	blue -	0 V
	black NO	I_{n_A} / I_{n_B}

Initiatoren NA 5002.01.34 and NA 5005.01.34 only usable for units without initiator-detection!